

## Wey Knife Gate Valve Model VL

High Performance Cast Stainless Steel

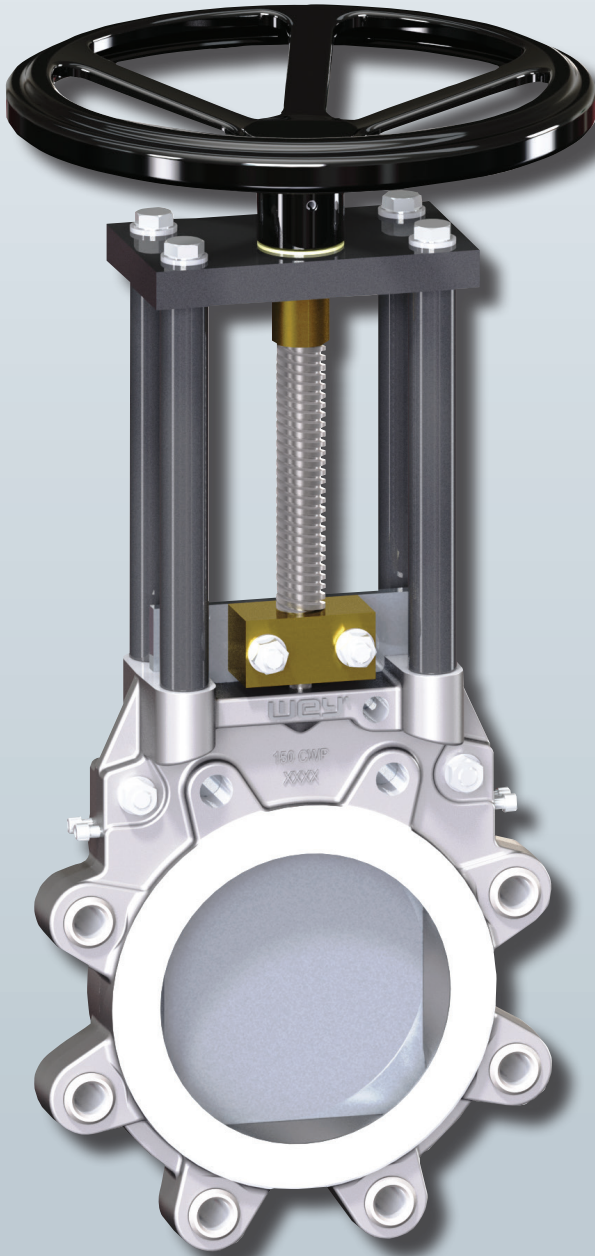

## Wey Knife Gate Valve Model VL

The Wey Knife Gate Valve Model VL is truly a high performance knife gate valve design. This valve provides **zero** leakage bi-directional shut-off, has mechanically retained seals, has a compact non-rising stem design, and can be repacked in service under full pressure. The chest and seating areas of the valve are self-cleaning. The reduced chest area, minimal gate arc, and contoured flushing corners in the body prevent jamming by eliminating material build-up in the chest, body and seating area. The gate seals against a combination metal and resilient seat and is guided for the full stroke length of the valve. The top "transverse" seal is repackable while in service under full pressure. The valve is tested and rated for **zero** leakage (liquid or gas) downstream and to atmosphere.

### Compare these unique features

Transverse seal eliminates stuffing box and permits repacking under full pressure and without system shut-down.

- Mechanically retained resilient seat provides dual metal-to-metal and resilient seating for **zero** leakage bi-directional shut-off from absolute vacuum to rated valve pressure.
- Bi-directional design. Gate is guided and supported for smooth operation throughout the entire stroke with flow in both directions.

- Contoured interior body promotes flushing action to prevent build-up of process media in the seating area.

- Solid steel or stainless steel topworks provide maximum strength to prevent damage due to operator abuse or vibrating conditions.

- Non-rising stem design saves space and reduces stem nut repair problems.

ISO 9001: 2008/PED-Annex III (Mod H)

### Characteristics

- Solid 316 SS cast lugged body
- 316 SS hard chrome finished gate
- Aflas® seals standard
- Phenolic Scraper Blades standard
- 2" - 36" size
- TAPPI & MSS-SP81 Face-to-Face
- 150 psi CWP design
- 2" - 12" 150 psi shut-off
- 14" - 36" 90 psi shut-off
- Higher pressure ratings available
- Other body, gate, scraper and seal materials available
- All styles of actuators available

The Model VL is specifically designed to meet the requirements of tough slurry, chemical and dry material handling applications. Typical applications include, but are not limited to, Pulp Stock, Air Conveyed Fly Ash and Cement, Waste Water, Abrasive Slurry and Sludge. These valves are successfully applied in the Pulp & Paper, Mining, Power, Steel, Municipal, Automotive, Chemical, Refining and Bulk Handling industries. There are applications for the VL product in virtually all industries.

The Model VL combines rugged construction with time-tested design features found in no other knife gate valve. If you are experiencing knife gate valve failures, try a precision-built Wey Knife Gate Valve. You will wish all of your knife gate valves were Wey High Performance Knife Gate Valves.



## Actuator options

Handwheel

Pneumatic cylinder

Electric actuator

Hydraulic actuator

All actuator units are interchangeable without dismantling valve from pipe system.

## Sizes and Dimensions

For optional Cylinder sizes and dimensions, consult the factory.

K = Cylinder port size 4" - 12" typ. Sistag Cyl.

N = Cylinder diameter not actual outside dimension

Note: Standard Cylinders are shown (other sizes are available)

O = Depth of Blind Tapped Holes in Chest Area of Valve

P = Number of Blind Tapped Holes in Chest Area of Valve

Note:

Bevel Gears (3:1) are recommended for 6"-10" Valves

Bevel Gears (4:1) are recommended for 12"-20" Valves

Bevel Gears (6:1) are recommended for 24" and larger Valves

Consult factory for special applications.

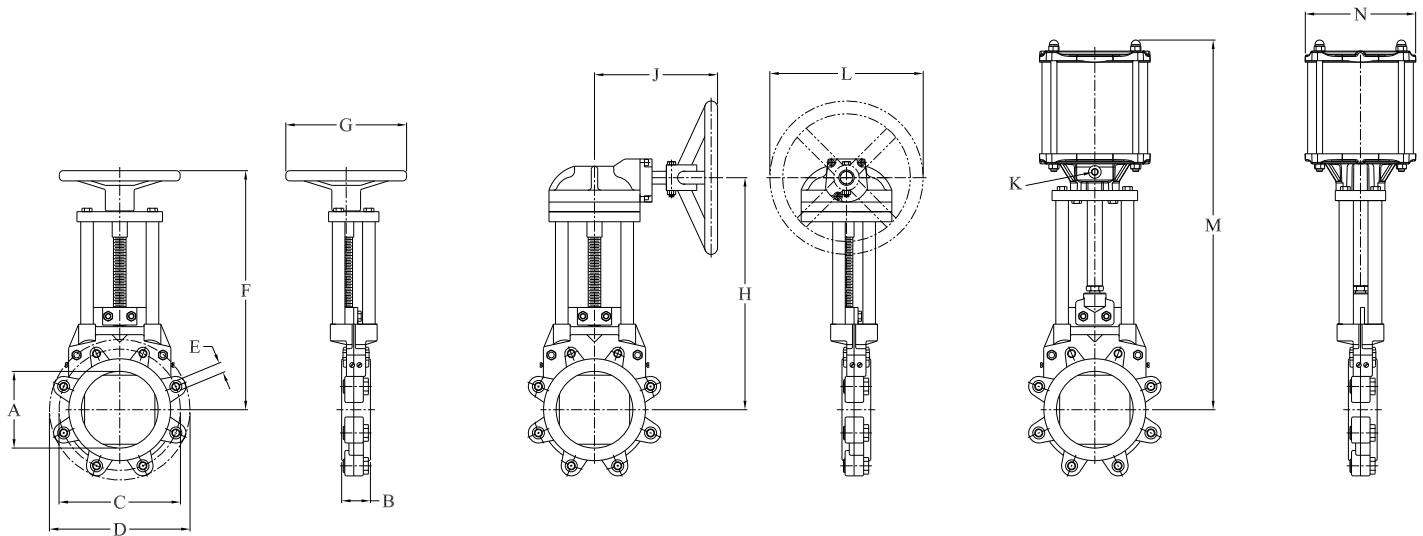

Handwheel

Bevel Gear

Air Cylinder

## Dimensions

Valve	A	B	C	D	E	F	G	H	J	K <sub>NPT</sub>	L	M	N	O	P
2"	1.97	1.87	4.75	6.00	5/8"	10.90	6.30	-	-	1/4"	-	15.25	4"	-	-
3"	3.15	2.00	6.00	7.50	5/8"	12.44	7.87	-	-	1/4"	-	17.80	4"	-	-
4"	3.94	2.00	7.50	9.00	5/8"	15.47	7.87	-	-	1/4"	-	20.75	4"	0.86	4
6"	5.90	2.25	9.50	11.00	3/4"	19.57	11.81	18.15	11.50	1/4"	12	27.28	6"	0.94	4
8"	7.84	2.75	11.75	13.50	3/4"	22.72	11.81	21.29	11.50	1/4"	12	32.40	6"	1.12	4
10"	9.87	2.75	14.25	16.00	7/8"	26.65	11.81	24.84	11.50	1/4"	16	38.90	8"	0.75	8
12"	11.81	3.00	17.00	19.00	7/8"	29.80	15.75	28.93	14.75	3/8"	16	44.21	10"	0.83	8
14"	13.78	3.00	18.75	21.00	1"	33.30	15.75	33.42	14.75	3/8"	18	54.25	10"	0.78	8
16"	15.75	3.50	21.25	23.50	1"	36.61	15.75	35.74	14.75	3/8"	18	61.50	12"	0.94	8
18"	17.72	3.50	22.75	25.00	1-1/8"	42.32	19.68	40.75	14.75	3/8"	18	67.50	12"	0.98	12
20"	19.68	4.50	25.00	27.50	1-1/8"	45.61	19.68	44.66	16.75	3/4"	24	74.25	14"	1.37	12
24"	23.62	4.50	29.50	32.00	1-1/4"	54.17	24.75	53.75	23.50	3/4"	24	86.25	16"	1.22	12
30"	29.52	4.62	36.00	38.70	1-1/4"	-	-	63.77	23.50	3/4"	24	97.50	16"	0.98	20
36"	35.43	4.62	42.75	46.00	1-1/2"	-	-	84.50	23.50	3/4"	30	111.50	18"	1.77	20

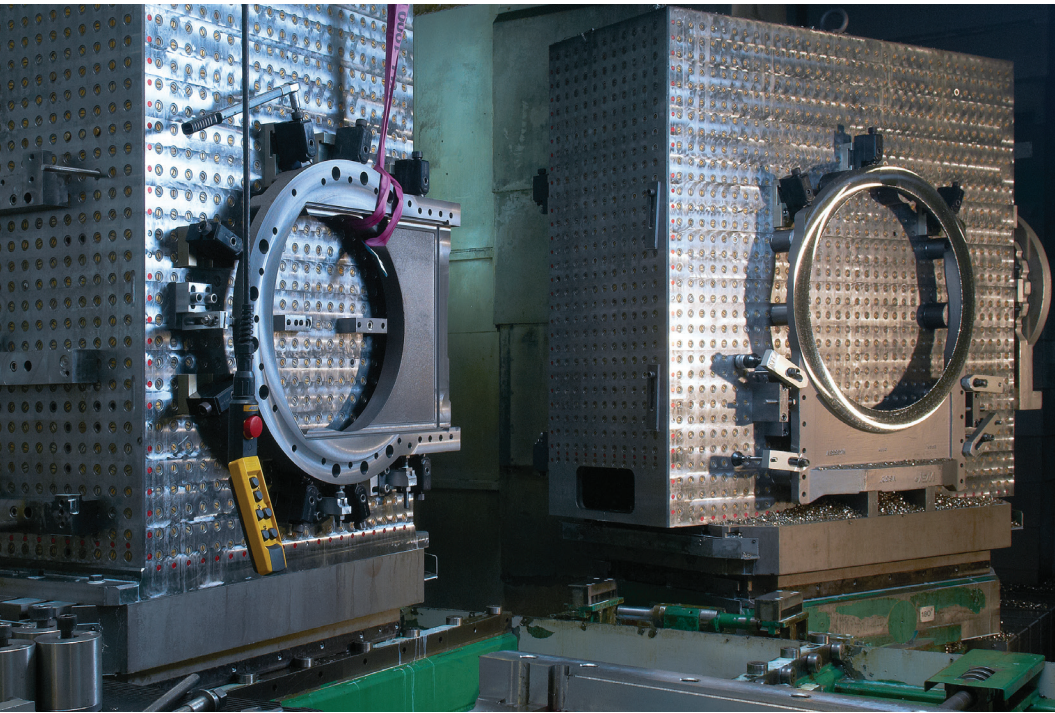

Large part machining  
with a 2 pallet CNC  
machining center

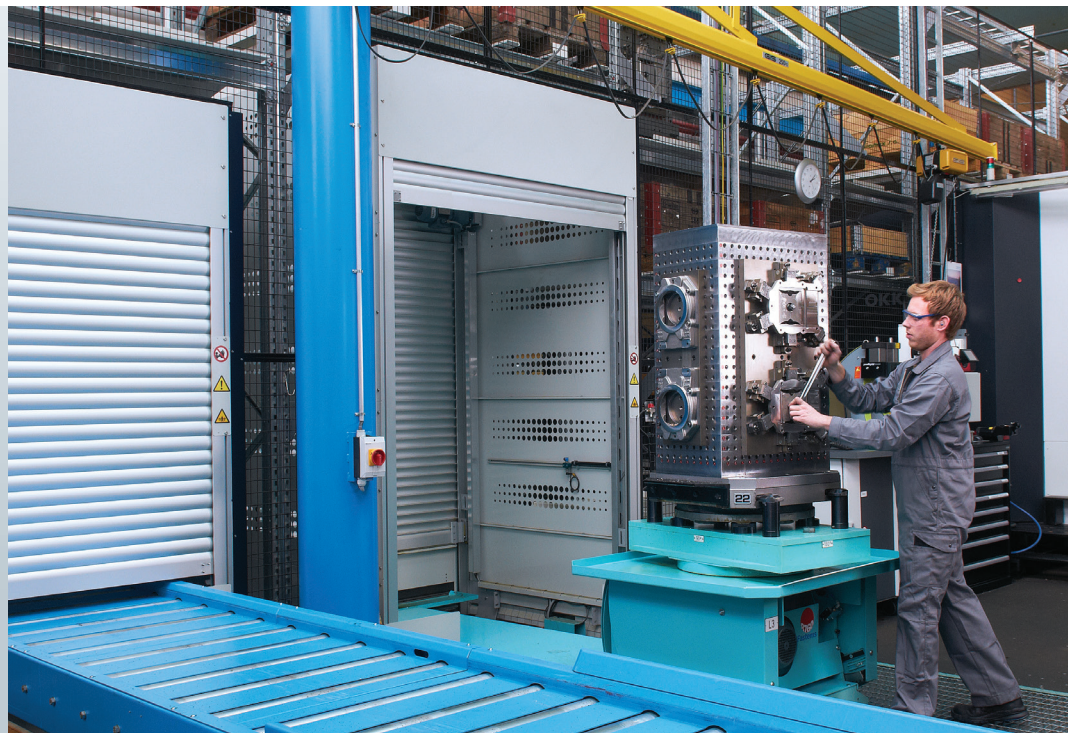

Flexible manufacturing  
system with intergrated  
material management

Your contact