

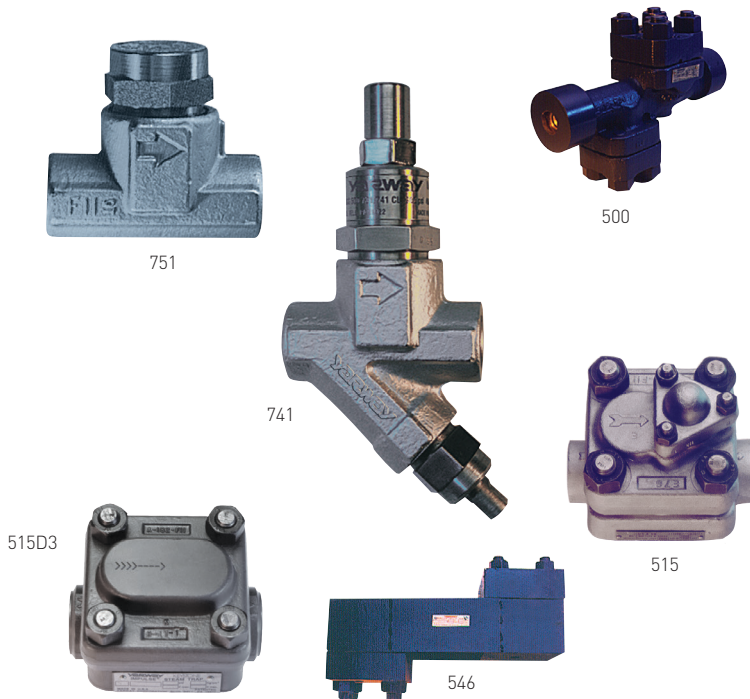

YARWAY REPAIRABLE DRIP AND TRACER STEAM TRAPS

SERIES 751/761, 711/721, 731/741, 500/546, 460/515/D3

Wide range of steam traps that provide consistent performance in less than perfect conditions



FEATURES

Thermostatic Traps

- Repairable
- Pressure assisted fail-open design
- Freeze proof
- Easy to check cyclic operation
- Discharge temperature follows saturation curve
- Energy efficient subcooled discharge
- Integral check valve and screen
- Hardened stainless steel valve body and seat
- Installation in any position
- Withstand superheat
- Operates against 99% back pressure

Thermodynamic Traps

- Repairable
- Easy to check cyclic operation
- Fail open design
- Self-draining (vertical mount)
- Energy efficient subcooled discharge
- Hardened stainless steel valve body and seat
- Single moving part
- Freeze proof
- Withstand superheat
- Unaffected by water hammer

GENERAL APPLICATION

Drip and tracer steam traps provide protection from condensate damage, temperature fluctuation, solidification, separation, and freezing, for steam lines, turbines, valves, risers, expansion loops, steam jacketing as well as pumps, while maintaining consistent performance in less than ideal conditions.

TECHNICAL DATA

Technology: Thermostatic
Thermodynamic

Size: 3/8", 1/2", 3/4", 1"
(DN 8, 10, 15, 20, 25)

Temperature: Max. design 900°F (482°C)

Pressure Rating: 1 to 4500 psig

Capacity: Up to 7500 lb/hr

Connections: Threaded
Socket weld

Materials: Low carbon chrome moly steel

YARWAY REPAIRABLE DRIP AND TRACER STEAM TRAPS

SERIES 751/761, 711/721, 731/741, 500/546, 460/515/D3

CONTENTS

Typical profile – Steam line drip	2-3
Typical profile – Tracer	4-5
The right trap for the right application	
Thermostatic	6
Thermodynamic	7
Variable orifice (piston).....	8-9
Thermostatic traps (Bellows) series 751/761	10-11
Thermodynamic traps	
Series 711/721 disc trap	12-13
Series 701-UC universal connector.....	14
Series 711-UC/721-UC universal connector.....	15
Variable Orifice (Piston) Series 731/741	16-17
High pressure	
Series C500 and C546.....	18-19
Series 460 and 515.....	20-21
Series 460D3 and 515D3.....	22-23

It all comes down to protection

Regardless of the temperature and pressure characteristics of steam line drips or tracers, there's one absolute requirement for any steam trap you choose - protection. Whether your system includes steam lines, turbines, control valves, risers, expansion loops, steam jacketed pipes, valves and pumps - or simply companion piping - a steam trap must offer protection day after day. More often than not, that also means consistent performance in less-than-perfect conditions. That's why it's important to understand your application in as much detail as possible before you select a drip or tracer steam trap. Variables such as steam pressure, condensate load, ambient conditions, air venting, shock, vibration, water hammer, dirt, and corrosion must be considered when making your trap selection for steam line drip, process line tracer, winterization tracer, instrumentation tracer, and steam jacketed tracing, as well as small process application.

TYPICAL PROFILE – STEAM LINE DRIP

Purpose: To remove condensate from piping to prevent damage to the piping and control valves, while assuring that production steam users receive dry steam.

Steam trap requirement: Adequately sized drip pockets on the bottom of piping or upstream of heat exchangers, collect condensate which then flows to the steam trap. The trap should discharge the condensate quickly.

Steam pressures and temperatures: Generally constant, with some seasonal variation. Of all industrial steam trapping applications, these are the higher pressures often exceeding 600 psi. Design pressures and operating pressures can be different and superheat is frequently encountered.

Condensate loads: Relatively small and constant while in normal operation, typically to 50 or 100 lb/hr. Startup loads can be heavier. Boiler carry-over produces slugs of condensate which are unpredictable in magnitude and frequency. Desuperheaters that are malfunctioning can produce unexpectedly high loads.

Drainage to trap: Usually by gravity with the steam trap installed below the steam line. Occasionally piping in trenches or underground have steam traps installed above the pipe, but the condensate collecting point is below the pipe. This is called lift drainage and requires a lift fitting.

Ambient conditions: Variable. Freezing is the more common concern.

Air Venting: Need is minimal. Pipe lines frequently have separate vents. Startup may present the most common need. Under running conditions, CO₂ may be a problem.

Shock, vibration, water hammer: Generally from inadequate drainage of condensate, which moves at high velocity (5000 - 10000 fpm). Thermal ratcheting may also occur at startup.

Dirt and Corrosion: If dirt and corrosion exist at the steam trap, consider what may be happening at the equipment being protected. A common source of foreign matter is packing used to seal leaks. The use of some amines and hydrazine can present "dirt" problems.

Steam trap installation: If bypasses around a trap station are installed and utilized during warm-up, consider installing a trap downstream of the steam blow if the bypass is left open.

Steam trap recommendation
Designed to fail open, self-draining, and installed in any position. Since condensate backup can be dangerous, a steam trap that responds quickly to condensate should be selected also. Tolerance to superheat must be considered. Operating capabilities over wide range of operating pressures is important to standardization.

YARWAY REPAIRABLE DRIP AND TRACER STEAM TRAPS

SERIES 751/761, 711/721, 731/741, 500/546, 460/515/D3

DRIP POCKET SIZE

Steam main size (in.)	Drip pocket diameter (in.)	
	Recommended	Range use in industry
1	1	1
2	2	1 - 2
4	4	1½ - 4
6	6	2 - 4
8	8	3 - 6
10	10	4 - 8
12	12	4 - 10
14	14	5 - 12
16	16	5 - 14
18	18	6 - 16
20	20	6 - 18
24	24	8 - 18

Drip pocket, 20% - 100% of steam main area.
8800 fpm = 100 mph.

STEAM LINE DRAINS

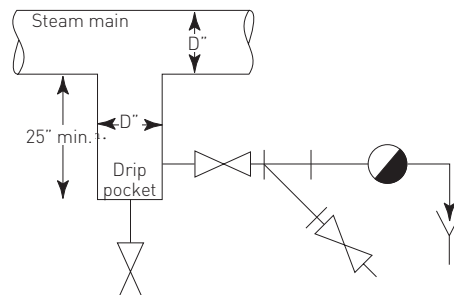

CONDENSATE LOAD, STEAM LINE DRIP, lb/hr PER 100 ft. OF PIPE

Normal conditions

Nominal pipe size (in.)	Operating steam pressure, psi					
	10	100	200	300	400	600
1	3	5	7	9	10	13
1½	4	8	11	13	15	19
2	5	10	13	16	19	24
3	8	15	20	24	28	35
4	10	19	26	31	36	45
6	15	29	38	46	53	66
8	20	38	50	60	69	87
10	25	47	62	75	87	108
12	30	56	74	89	103	128
14	33	62	81	98	113	141
16	38	70	93	112	129	161
18	43	79	105	126	145	181
20	48	88	116	140	161	202
24	57	106	140	168	194	242

NOTES

1. Assumed conditions: Ambient, 0°F; Saturated steam, Zero (0) wind velocity; Pipe surface temperature same as steam temperature. Insulation 85% efficient.
2. Ambient temperature, wind and rain can influence loads.

CONDENSATE LOAD, STEAM LINE DRIP, lb/hr PER 100 ft. OF PIPE

Warm up conditions

Nominal pipe size (in.)	Operating steam pressure, psi					
	10	100	200	300	400	600
1	14	16	17	19	19	20
1½	17	20	22	24	26	29
2	30	35	38	40	46	48
3	60	69	74	78	81	92
4	93	99	107	113	126	131
6	166	185	198	208	220	239
8	250	277	298	313	329	357
10	315	352	375	395	415	449
12	337	419	448	472	495	541
14	416	461	493	519	545	591
16	478	532	578	592	628	681
18	536	596	638	670	703	763
20	605	673	719	757	793	860
24	721	802	857	900	945	1024

NOTES

1. Assumed conditions: Warm-up rate, 400°F/hr Ambient, 0°F; Insulation 85% efficient; Extra strong pipe; Wind, 0 mph; 10% additional load for warming insulation; 50% of running load.
2. Ambient temperature, wind and rain can influence loads

YARWAY REPAIRABLE DRIP AND TRACER STEAM TRAPS

SERIES 751/761, 711/721, 731/741, 500/546, 460/515/D3

TYPICAL PROFILE – PROCESS LINE TRACER, WINTERIZATION TRACER, INSTRUMENTATION TRACER, AND STEAM JACKETED TRACING

PROCESS PIPE LINES AND WINTERIZATION TRACING

Before installing any trap, make sure you consider these potential problems:

Ambient conditions outdoors, freezing wind and rain are considerations.

Drainage to trap usually by gravity. Lift is sometimes encountered and this requires special treatment.

Air venting modest need, only on startup, which is infrequent.

Shock, Vibration, Water hammer modest. If severe, it usually comes from the return system, or improperly trapped team supply.

Dirt and corrosion generally modest unless using copper tubing. Then the plating of dissolved solids is a frequent problem.

Base conditions: dry

- Steam pressure, P_s 100 psi
- Steam temperature, T_s Sat.
- Ambient temperature, T_a 0F
- Wind velocity 0 mph
- Insulation efficiency, E 85%
- Pipe material Steel
- Heat transfer coefficient, $U = 3$

LOAD PER 100 ft. OF PIPE LINE

Product line diameter (in.)	Condensate load, lb/hr per 100 ft.
1	1.50
1½	2.00
2	2.26
2½	2.65
3	3.00
4	3.68
6	5.10
8	6.43
10	7.80
12	9.20
16	11.36
20	14.03
24	16.71

SUGGESTED MAXIMUM STEAM TRACER LENGTH FOR VARYING PRESSURES, CONDENSATE LOADS AND TRACER SIZES, PROCESS AND WINTERIZATION TRACING

Load #/hr per 100 ft	Tracer length (ft) for ½" tubing at various pressures						
	10 psi	30 psi	50 psi	100 psi	150 psi	200 psi	300 psi
10	76	113	144	211	268	320	413
20	49	72	92	135	172	206	266
40	30	44	57	83	106	127	163
60	23	34	43	64	81	97	125

Steam trap recommendation

Fail open, self draining, small and light-weight; capable of being installed in any position desirable. This is due to the fact that tubing is frequently used for tracing and is left free to "dangle." There can be many traps installed on this application, so a trap that is easily checked and maintained is desirable.

A hot, fast responding trap or a subcooled, slow responding trap can be used dependent upon the specific application. The quality of the insulation, length of run, and standardization to prevent application errors may be the deciding factor. If subcooled traps are used, consider the potential for freezing.

YARWAY REPAIRABLE DRIP AND TRACER STEAM TRAPS

SERIES 751/761, 711/721, 731/741, 500/546, 460/515/D3

TYPICAL PROFILE - WINTERIZATION TRACER, PROCESS LINE TRACER

WINTERIZATION

Purpose: The heat of steam is used to protect water lines from freezing in cold weather. The water lines are those that are out of doors, and frequently have no flow, making them vulnerable to freezing. Examples include safety showers, eye washes, fire equipment, stand-by pumps, and domestic water supplies. Can include seasonal process tracing in warmer climates.

Application: Usually tubing is mounted on the water line, pump or valve to be protected. The system may or may not be insulated. Overheating may be a concern.

Steam pressures: Usually in the range of 40-150 psi. Lower pressures may be encountered. Pressures may change seasonally with on-off operation of the steam supply, which can produce the need for air-venting and heavier start-up loads.

Condensate loads: Generally low with normal running loads on the order of 20 lb/hr. Heavier loads maybe encountered due to start-ups, lack of insulation, or long runs of tracing.

Steam trap recommendation

Fail open, self draining, small and light-weight: capable of being installed in any position desirable. This is due to the fact that tubing is frequently used for tracing and is left free to "dangle". There can be many traps installed on this application, so a trap that is easily checked and maintained is desirable. A hot, fast responding trap or a subcooled, slow responding trap can be used dependent upon the specific application. The quality of the insulation, length of run, and standardization to prevent application errors may be the deciding factor. If subcooled traps are used, consider the potential for freezing.

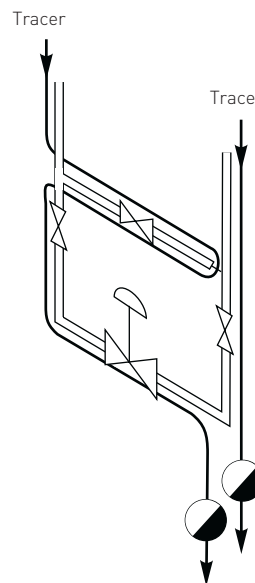

PROCESS LINE TRACER

Purpose: Steam is used to maintain heat in a process line. The heat is needed at or in a pipe line carrying some process material like asphalt, sulfur, wax, chemical, or gas. The heat is needed to maintain viscosity, prevent congealing, solidification or separation. Rarely is the heat used for warming up lines, but mostly for maintaining a temperature.

Application: small diameter pipe(s) or tube(s) external to and parallel to a product line that requires heat. The heat of steam flows from the tracer to the product line. Steam condenses in the tracer and runs out the end of the small pipes or tubes into a steam trap. The trap discharges the condensate.

Steam pressures: generally, the highest of steam tracing with 150 psi typical. Pressures to 400 psi are possible. Pressures are constant with possible season variations. Insulation quality may be a significant factor.

Condensate loads: generally low and constant with changes due to seasonal and/or insulation quality. Typical loads are 10-50 lb/hr. depending on tracer diameter, length, installation, insulation, and ambient conditions.

Traced valve and piping

Steam trap recommendation: Fail open, self draining, small and light-weight, since traps are frequently attached to tubing. The trap should be capable of being installed in any position because the tubing is any position because the tubing is frequently allowed to "dangle". A hot trap with fast response is desired to maintain the usually high temperatures needed for the product within the process line. Because there can be many traps in this application, a trap that is easily and quickly checked and maintained is desirable.

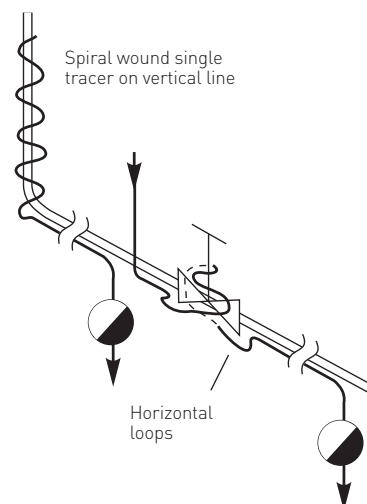

YARWAY REPAIRABLE DRIP AND TRACER STEAM TRAPS

SERIES 751/761, 711/721, 731/741, 500/546, 460/515/D3

THE RIGHT TRAP FOR THE RIGHT APPLICATION

It is important to use the correct technology to match your application criteria, so Yarway has developed a full line of non-renewable drip and tracer steam traps, designed to solve your special application needs. Featuring both thermostatic and thermodynamic designs, these two models offer a full range of operating capabilities.

THERMOSTATIC

Yarway offers two thermostatic steam traps for drip and tracer applications:

- Series PB-5
- Series PB-40

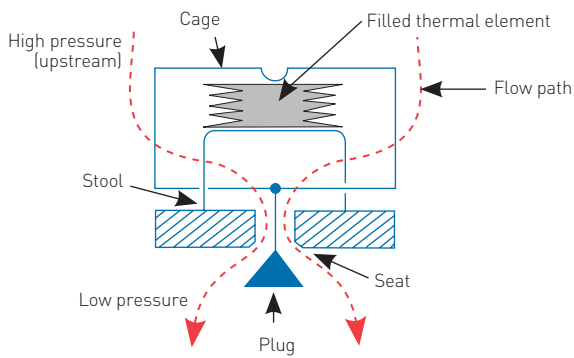

Valve open to non-condesibles and cool condensate

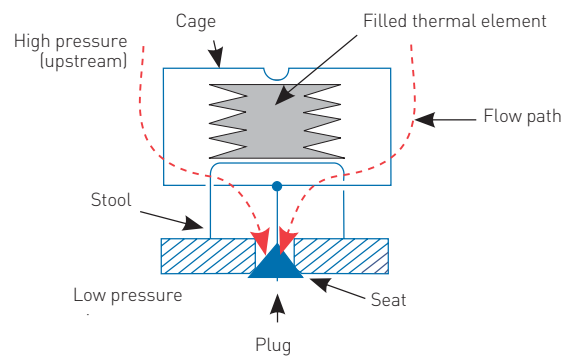

Valve closed to hot condensate or steam

How it works

The thermostatic filled thermal element actuator opens or closes the internal valve as condensate temperature changes. Steam is prevented from discharging through the trap and only condensate is discharged. The trap discharges condensate with a cyclic action under moderate load. Under certain conditions of low load and/or low pressure, the trap may discharge continuously. The valve also acts as a check valve against reverse flow.

These thermostatic steam traps are Filled Thermal Element (FTE) actuated. Unlike most thermostatic traps which provide a modulating response, the PB traps tend to operate in an on-off cyclic mode. This makes operation of these traps easy to check visually and by sound. The patented design which promotes cyclic action also helps keep the plug and seat of the trap clear of debris, thus minimizing the opportunity for either the seat or plug to become wiredrawn. Failure of the actuator from any cause results in a pressure-assisted, permanent fail-open position of the plug. Unlike other thermostatic traps, this condition cannot be subsequently compromised by line pressure. The piping system therefore gains reliable protection.

All Yarway thermostatic traps deliver consistent features such as:

- Three-year warranty
- Pressure assisted fail-open design
- Freeze proof
- Easy-to-check cyclic operation
- Discharge Temperature follows the saturation curve
- Subcooled discharge provides energy efficiency
- Integral check valve and screen
- Hardened stainless steel valve and seat
- Installation in any position
- Withstands superheat
- Operates against 99% back pressure

YARWAY REPAIRABLE DRIP AND TRACER STEAM TRAPS

SERIES 751/761, 711/721, 731/741, 500/546, 460/515/D3

THERMODYNAMIC

Yarway offers three disc traps for drip and tracer applications:

- Series 29
- Series 129Y (Y Strainer)
- Series 29S (T Strainer)

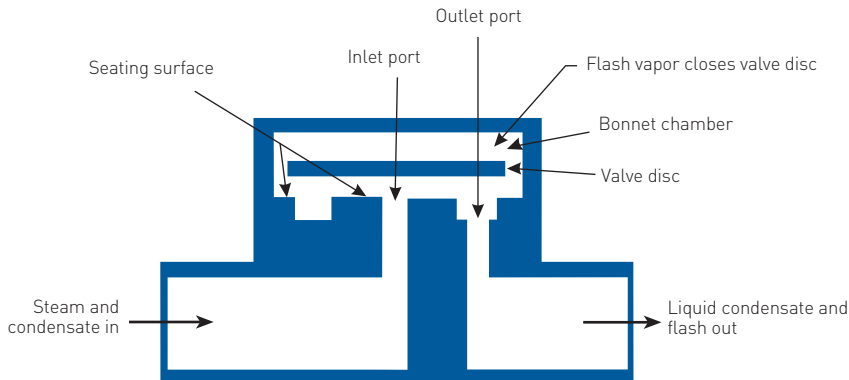

How it works

Disc traps use the energy in hot condensate and steam to open and close the valve disc. The trap senses the difference between cool and hot liquid, and gases or vapors. During initial start-up, pressure created by cold condensate pushes the valve disc off the seating surface. This uncovers the inlet and outlet ports, allowing discharge. As condensate reaches the inlet port, it experiences a decrease in pressure and an increase in velocity. As the condensate is very close to steam temperature, the lower pressure will cause it to flash into steam. The resulting high velocity flow beneath the disc, with its attendant localized pressure reduction under the disc, causes it to snap shut. Flow through the trap then stops until the pressure in the chamber over the disc decays sufficiently to allow the inlet pressure to force the disc off its seat. Condensate then flows through the trap until once again it reaches such a velocity and lowering of pressure that flashing occurs and the disc can snap shut. This cycle continuously repeats itself. A key feature is the closing on flashed condensate, maintaining a water seal and preventing steam loss.

All Yarway thermodynamic traps deliver consistent features such as:

- Easy to check cyclic operation
- Designed to fail open
- Self-draining (vertically mounted)
- Energy efficient subcooled operation
- Hardened, rugged stainless steel internals
- Installation in any position
- One moving part
- Stainless steel body
- Unaffected by freezing
- Unaffected by water hammer
- Designed for superheat

YARWAY REPAIRABLE DRIP AND TRACER STEAM TRAPS

SERIES 751/761, 711/721, 731/741, 500/546, 460/515/D3

VARIABLE ORIFICE (PISTON)

Yarway offers three variable orifice traps for drip and tracer applications:

- Series 731/741
- Series 460/515
- Series C-500/546

All Yarway variable orifice traps deliver consistent features such as:

- Designed to fail open
- Energy efficient
- Hardened, rugged stainless steel internals
- Installation in any position
- Quick change trim
- Forged chrome-moly body
- Freeze-resistant
- Unaffected by water hammer
- Designed for superheat

How it works

Variable orifice traps differentiate between the energy in cool condensate and flashing condensate as well as gases. Cool condensate opens the valve because the pressure in the chamber above the valve is low. The cool condensate readily drains through the control orifice from the chamber. Hot flashing condensate chokes the flow in the orifice and raises the chamber pressure. The increased chamber pressure closes the valve. When the valve is closed, a small amount of condensate continuously drains through the control orifice, making the trap responsive to changes in condensate load.

Guidelines for typical applications

Depending on the application, a steam trap will probably have to handle heavy startup loads, often followed by smaller running loads. The trap's function is to drain the process equipment and thus ensure that effective heat transfer is achieved (through latent heat).

A few guidelines for optimum results include:

- Provide an adequate size process connection from equipment;
- Locate trap below the equipment (water runs downhill);
- Use good piping practice to ensure that clean condensate is presented to the trap;
- Include air vents and vacuum breakers as necessary for effective equipment operation.

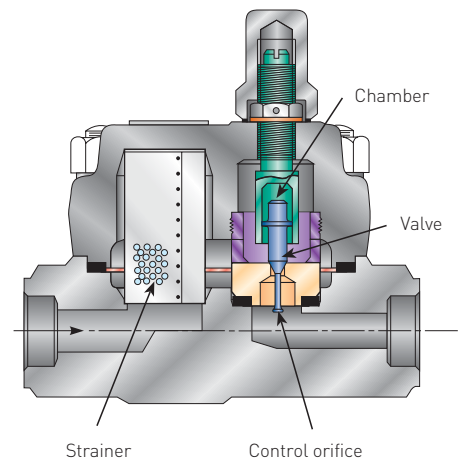

YARWAY REPAIRABLE DRIP AND TRACER STEAM TRAPS

SERIES 751/761, 711/721, 731/741, 500/546, 460/515/D3

STEAM MAIN DRIP AND TURBINE DRAIN

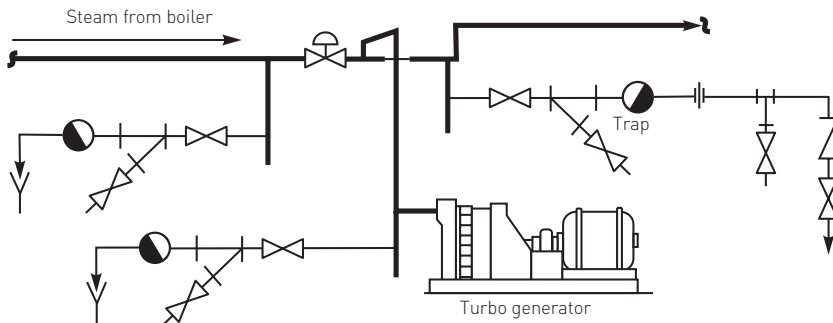

These critical applications require a hot running thermodynamic steam trap that is responsive to sudden load change. These traps are essentially installed for protection insurance and normally only will need to handle a low condensate load, because superheated steam is usually used. Should a slug of condensate appear, the traps must be very responsive, in order to ensure that the condensate does not get passed to the turbine.

SUBMERGED COIL (SYPHON/LIFT DRAINAGE)

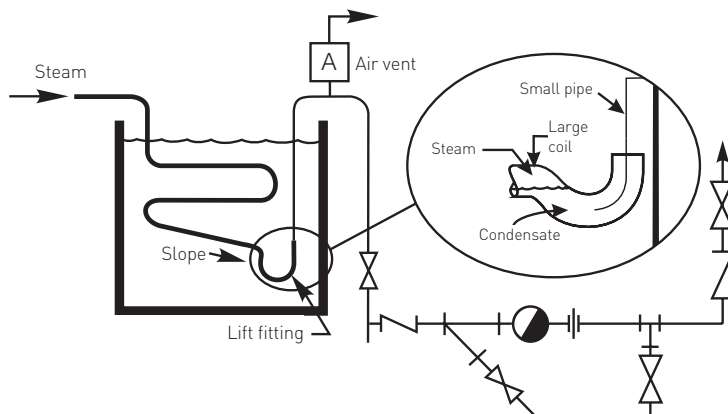

Liquids, slurries or materials are heated or cooked in jacketed kettles, tanks or pits with submerged coils. All require raising the condensate to the trap. Condensate is brought to the trap through the use of a lift fitting which creates a water seal, or reaches the trap through a syphon tube as in the case of a tilting kettle. Equipment is generally protected from the weather and unlikely to see extreme temperatures, either hot or cold. Frequent start-ups and the need to get the equipment hot quickly requires good air venting.

YARWAY REPAIRABLE DRIP AND TRACER STEAM TRAPS

SERIES 751/761, 711/721, 731/741, 500/546, 460/515/D3

SERIES 751/761 THERMOSTATIC TRAPS (BELLOWS)

The series 751/761 is available in two body designs and with three Filled Thermal Elements (FTEs). The series 761 is an in-line body with an integral wye strainer and blowdown valve. The series 751 is an in-line body only. The FTEs to 300 psi are the -5 for drip tracing and light process; the -40 for tracing. The -HP is for applications to 600 psi. The FTEs are available in factory set and assembled renewal kits.

All internals are energy efficient. The -5 and -HP internals are slightly subcooled operating near steam temperature. The -40 internals operate 35°F to 45°F subcooled. The -HP is recommended for optimum service life limited to 450 psig.

Applicable codes and standards

Pressure ratings per ANSI/FCI-69-1
Performance testing per ANSI/ASME PTC-39.1
End connections per ANSI B1.20.1 for threaded ends, per ANSI B16.11 for socket-welding ends.

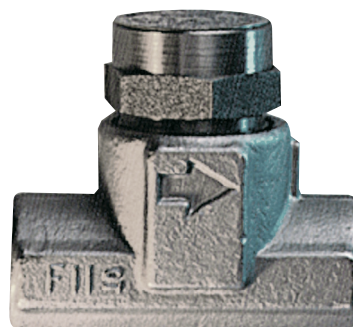

CAPACITIES (FOR STEAM TRAP SIZING)

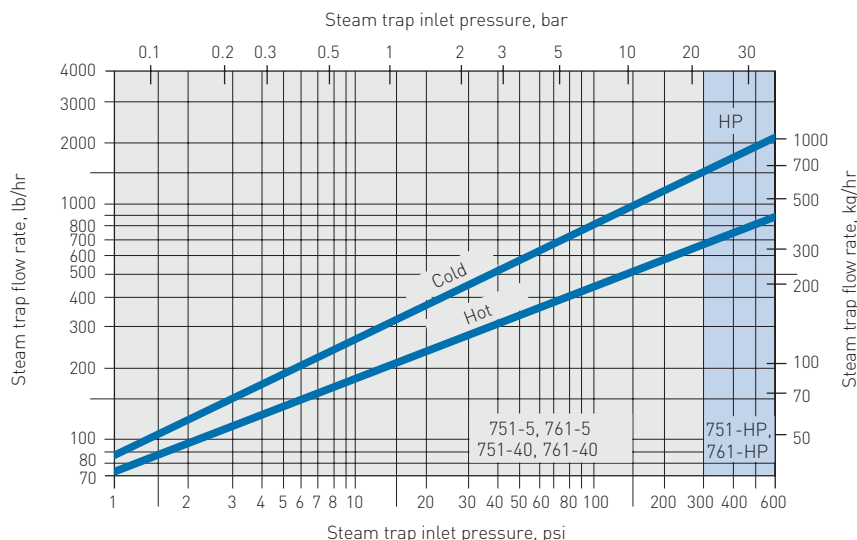

HOW TO SPECIFY AND ORDER

Typical specification - traps shall be thermostatic rated to 600 psi and actuated by a FTE stainless steel. The body shall be low carbon (0.15 max c) chrome-moly steel with threaded (socket-welding) end connections.

Ordering - specify trap pipe size, series number, FTE rating, and the type of end connections desired (threaded or socket-welding). The renewal capsule consists of a factory-calibrated FTE cage assembly, seat and bonnet, with seat gasket. Order by specifying: Renewal capsule for series 751/761 trap.

FUNCTIONAL SUPERHEAT DESIGN LIMITS

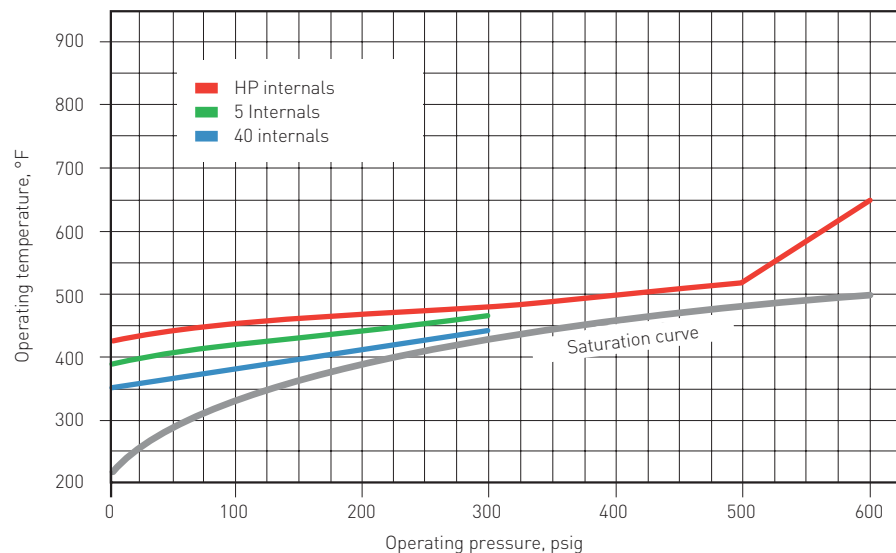

PRESSURE/TEMPERATURE RATINGS

	751/761-5, -40	751/761-HP
Shell rating	600 psi	600 psi
Max. design Temperature	750°F (400°C)	750°F (400°C)
Max. operating Pressure	300 psi (21 bar)	600 psi (41 bar)
Min. operating Pressure	1 psi (0.07 bar)	1 psi (0.07 bar)
Operating temperature	See chart	

YARWAY REPAIRABLE DRIP AND TRACER STEAM TRAPS

SERIES 751/761, 711/721, 731/741, 500/546, 460/515/D3

SERIES 751/761 THERMOSTATIC TRAPS (BELLOWS)

SERIES 751

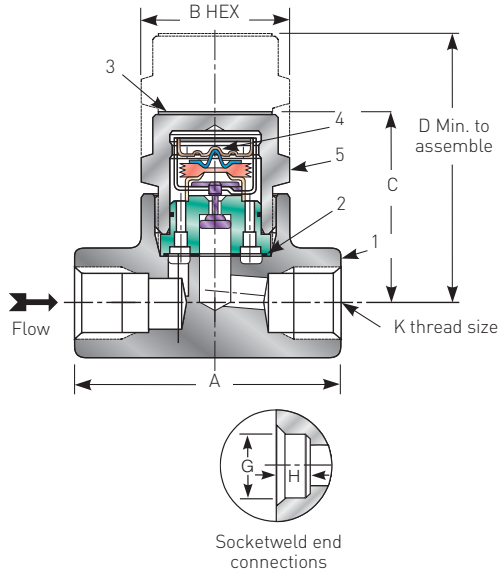

SERIES 761

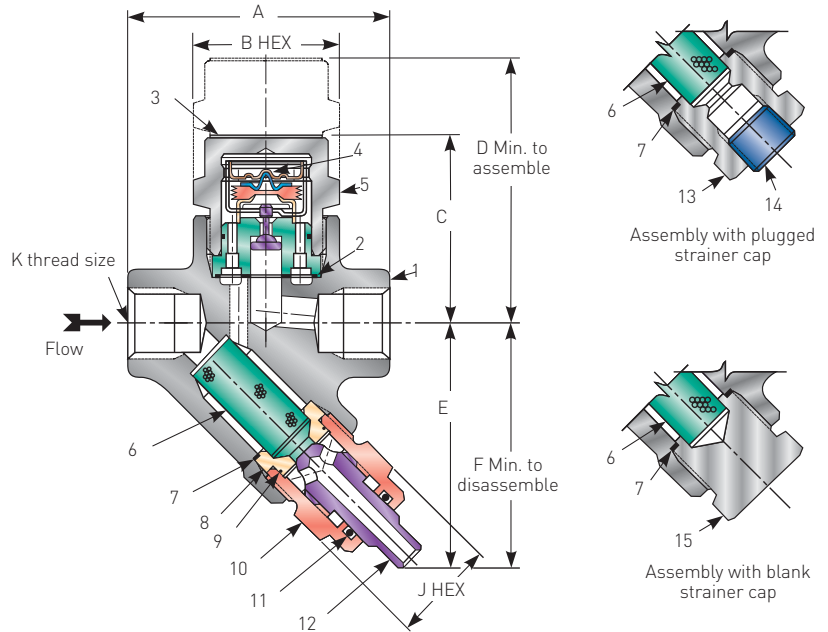

PARTS AND MATERIALS

Item	Part	Materials
1	Body	ASME SA-182 GR. F11 low carbon, 0.15 max C
2 ^[1]	Seat gasket	Clad non-asbestos
3 ^[1]	Nameplate	Stainless steel
4 ^[1]	FTE cage assembly	Stainless steel
5 ^[1]	Bonnet	ASTM A-582 Type 416 stainless steel
6	Screen	Stainless steel
7 ^[2]	Cap gasket	Monel®
8 ^[2]	Blowdown seat	416 stainless steel
9 ^[2]	Retaining ring	17-7 PH stainless steel
10 ^[2]	Blowdown body	416 stainless steel
11 ^[2]	O-ring	Silicone
12 ^[2]	Blowdown valve	416 stainless steel
13 ^[3]	Strainer cap	416 stainless steel
14 ^[3]	Plug 3/8 NPT	Carbon steel A-105
15 ^[3]	Blank strainer cap	416 stainless steel

NOTES

1. Part of factory assembled renewal capsule.
2. Factory assembled blowdown valve renewal kit.
3. Optional strainer caps.

DIMENSIONS AND WEIGHTS

Trap size in. (DN)	Nominal dimensions, in. (mm)											Weight lb. (kg)	
	A	B	C	D	E	F	G	H	J	K	Series 751	Series 761	
3/8 [10]	3 ⁵ / ₃₂ (80)	1 1/2 (38)	2 ³ / ₁₆ (56)	3 (76)	2 ⁷ / ₈ (73)	3 ¹⁵ / ₁₆ (100)	3/8 (9.5)	0.695 (17.6)	1 1/16 (27)	3/8 NPT	2 (0.9)	2 3/4 (1.3)	
1/2 [15]	3 ⁵ / ₃₂ (80)	1 1/2 (38)	2 ³ / ₁₆ (56)	3 (76)	2 ⁷ / ₈ (73)	3 ¹⁵ / ₁₆ (100)	3/8 (9.5)	0.860 (21.8)	1 1/16 (27)	1/2 NPT	2 (0.9)	2 3/4 (1.3)	
3/4 [20]	3 ³⁵ / ₆₄ (90)	1 1/2 (38)	2 1/4 (57)	3 1/16 (78)	3 1/4 (83)	4 ¹⁵ / ₁₆ (110)	1/2 (12.7)	1.070 (27.2)	1 3/16 (30)	3/4 NPT	2 1/2 (1.2)	3 1/4 (1.5)	
1 [25]	3 ¹⁵ / ₁₆ (100)	1 1/2 (38)	2 1/4 (57)	3 1/16 (78)	3 3/8 (86)	4 ⁷ / ₁₆ (113)	1/2 (12.7)	1.335 (33.9)	1 3/16 (30)	1 NPT	2 3/4 (1.3)	4 (1.8)	

YARWAY REPAIRABLE DRIP AND TRACER STEAM TRAPS

SERIES 751/761, 711/721, 731/741, 500/546, 460/515/D3

SERIES 711/721 DISC TRAP (THERMODYNAMIC)

The series 711/721 unibody plus disc trap is designed for light load applications such as steam tracing, steam line drip, and turbine drain. These traps are fully renewable in-line, energy efficient and easy to check.

The 711 is a simple straightway body. The 721 is a straightway body and has an integral wye strainer and blowoff valve. Both bodies accept the same renewal capsules without removing the bodies from the line. The standard capsule performs best when applied in service up to 450 psig. The HP capsule has been designed for 150-650 psig service to handle low load superheat service conditions.

Ratings

Design: 600 psig, 750°F
 Operating: 4 to 450 psig/750°F
 (0.3 to 31 bar/400°C)

711HP/721HP only

Design: 650 psig, 750°F
 Operating: 150 to 650 psig/750°F
 (10.3 to 45 Bar/400°C)
 Back pressure to 80% of inlet, psia

Applicable codes and standards

Pressure rating per ANSI/FCI-69-1.
 Performance testing per ANSI/ASME PTC-39.1.
 End connections per ANSI B1.20.1 for threaded ends, per ANSI B16.11 for socket-welding ends.



HOW TO SPECIFY AND ORDER

Typical specification - trap shall be inline renewable "zero steam loss" disc-type thermodynamic trap with low carbon (0.15% max.) chrome moly body in ASME SA-182 GR. F-11 and stainless steel trim. End connections shall be threaded or socket-welding. Trap shall have replaceable capsule. When specifying series 721, add "Trap shall have an integral strainer with stainless steel screen and integral blow-off valve."

CONDENSATE CAPACITY NEAR STEAM TEMPERATURE (for steam trap sizing)

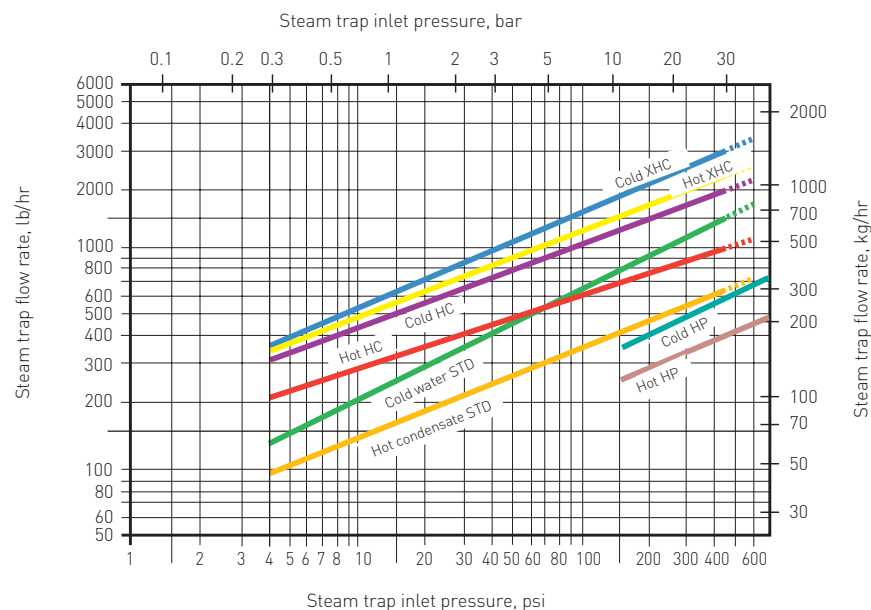

YARWAY REPAIRABLE DRIP AND TRACER STEAM TRAPS

SERIES 751/761, 711/721, 731/741, 500/546, 460/515/D3

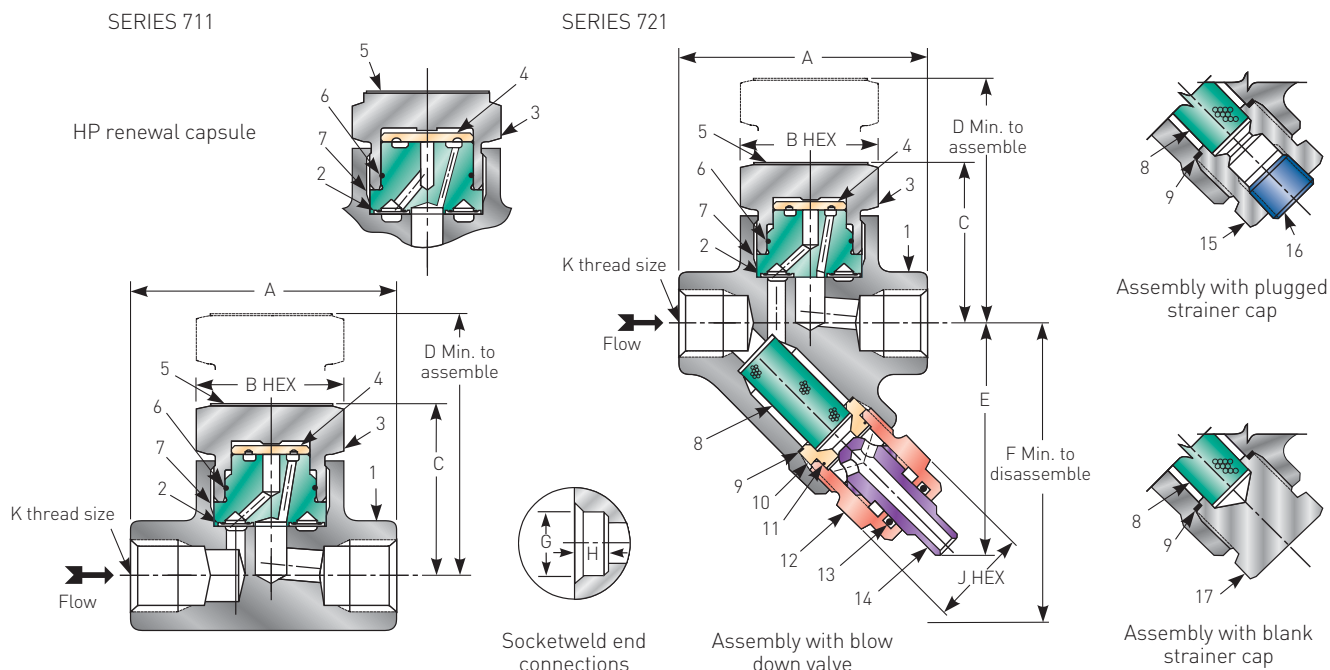

PARTS AND MATERIALS

Item	Part	Material
1 ^[1]	Body	Chrome moly, 0.15% max C ASME SA-182 GR. F-11
2 ^[2]	Seat gasket	Clad non-asbestos
3 ^[2]	Bonnet	Stainless steel ASTM A-582 Type 416
4 ^[2]	Disc	Stainless steel HT
5 ^[2]	Nameplate	Stainless steel
6 ^[2]	Retaining ring	Stainless steel 17-7 PH
7 ^[2]	Seat	Stainless steel HT
8	Screen	Stainless steel 0.020 perf.
9 ^[3]	Cap gasket	Monel [®]
10 ^[3]	Blowdown seat	416 stainless steel
11 ^[3]	Retaining ring	17-7 PH stainless steel
12 ^[3]	Blowdown body	416 stainless steel
13 ^[3]	O-ring	Silicone
14 ^[3]	Blowdown valve	416 stainless steel
15 ^[4]	Strainer cap	416 stainless steel
16 ^[4]	Plug 3/8 NPT	Carbon steel A-105
17 ^[4]	Blank strainer cap	Stainless steel

NOTES

- Optional weather cap for outdoor use.
- Part of factory assembled renewal capsule.
- Factory assembled blowdown valve renewal kit.
- Optional strainer caps.

DIMENSIONS AND WEIGHTS

Trap size in. (DN)	Nominal dimensions, in. (mm)										Weight lb. (kg)	
	A	B	C	D	E	F	G	H	J	K	Series 711	Series 721
3/8 [10]	3 5/32 [80]	1 1/2 [38]	1 15/16 [49]	2 11/16 [68]	2 7/8 [73]	3 15/16 [100]	0.695 [17.6]	3/8 [9.5]	1 1/16 [27]	3/8 NPT	1 1/2 [0.7]	2 1/4 [1.1]
1/2 [15]	3 5/32 [80]	1 1/2 [38]	1 15/16 [49]	2 11/16 [68]	2 7/8 [73]	3 15/16 [100]	0.860 [21.8]	3/8 [9.5]	1 1/16 [27]	1/2 NPT	1 1/2 [0.7]	2 1/4 [1.1]
3/4 [20]	3 35/64 [90]	1 1/2 [38]	1 15/16 [49]	2 11/16 [68]	3 1/4 [83]	4 5/16 [110]	1.070 [27.2]	1/2 [12.7]	1 3/16 [30]	3/4 NPT	2 [0.9]	2 3/4 [1.3]
1 [25]	3 15/16 [100]	1 1/2 [38]	1 15/16 [49]	2 11/16 [68]	3 3/8 [86]	4 7/16 [113]	1.335 [33.9]	1/2 [12.7]	1 3/16 [30]	1 NPT	2 1/4 [1.1]	3 1/2 [1.6]

YARWAY REPAIRABLE DRIP AND TRACER STEAM TRAPS

SERIES 751/761, 711/721, 731/741, 500/546, 460/515/D3

UC (UNIVERSAL CONNECTOR)

Yarway's all position Universal Connector (UC) with two bolt adapter allows for easy replacement of Yarway capsules inline.

The Universal Connector is designed for standard Yarway capsules as well as Armstrong, Sarco, Watson McDaniel and TLV traps that utilize all position connectors.

Additionally, the Universal Connector can easily be upgraded to Yarway's Unibody Plus line of capsules - Thermostatic (751-UC), and Piston (731-UC).

Complete factory assembled Universal Connector Yarway Steam Traps are also available that include: Universal Connector, Two bolt adapter and capsule.

DIMENSIONS, inches

Trap series	D	E
711-UC-F2 Disc		
721-UC-F2 Disc	3 ¹ / ₁₆	3 ¹³ / ₁₆
731-UC-F2 Piston		
741-UC-F2 Piston	5 ³ / ₁₆	5 ¹⁵ / ₁₆
751-UC-F2 FTE		
761-UC-F2 FTE	4 ³ / ₁₆	4 ¹⁵ / ₁₆

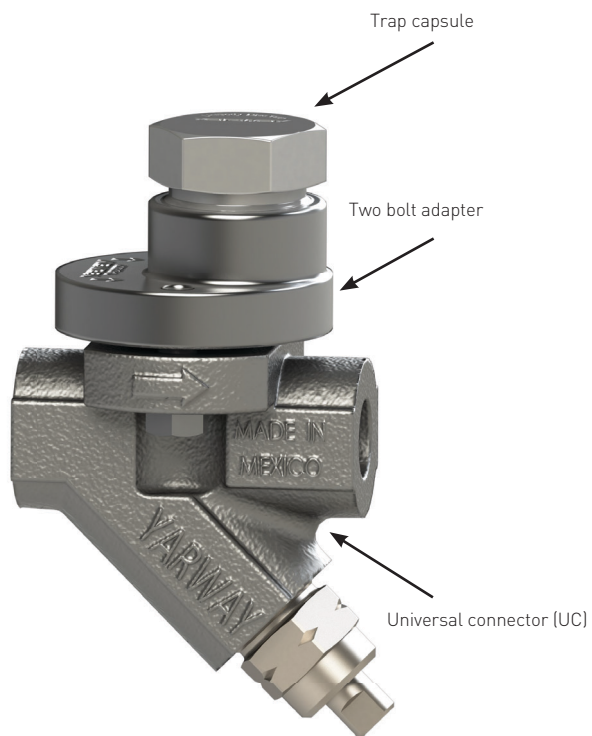

Series 751-UC trap capsule



Series 731-UC trap capsule

YARWAY REPAIRABLE DRIP AND TRACER STEAM TRAPS

SERIES 751/761, 711/721, 731/741, 500/546, 460/515/D3

SERIES 711-UC/721-UC DISC TRAP (THERMODYNAMIC)

HP renewal capsule

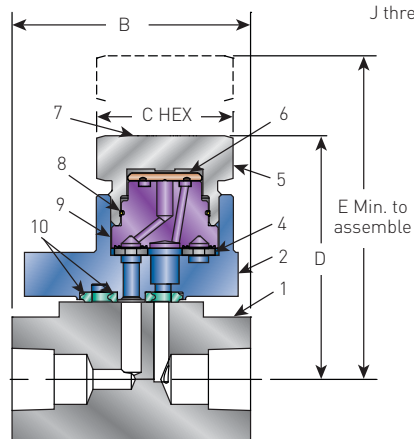
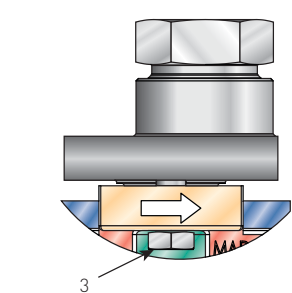

SERIES 711-UC

SERIES 721-UC

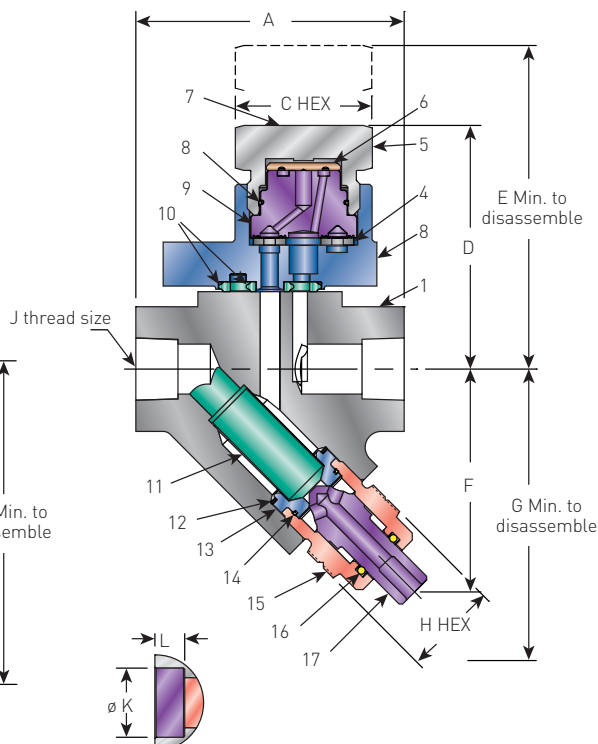

Socketweld end connections

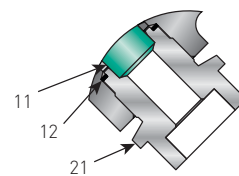

Assembly with socketweld strainer cap

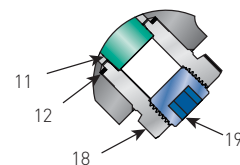

Assembly with plugged strainer cap

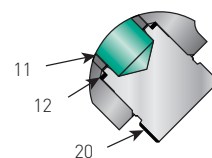

Assembly with blank strainer cap

PARTS AND MATERIALS

Item	Part	Material
1	Body	Cast chrome moly ASTM A217 WC9
2	Unibody adapter	Stainless steel Type 304
3	Hex bolt	ASTM A193 Grade B7
4 ^[1]	Gasket	Clad non-asbestos
5 ^[1]	Bonnet	Stainless steel Type 416
6 ^[1]	Disc	Stainless steel, HT
7 ^[1]	Nameplate	Stainless steel
8 ^[1]	Retaining ring	Stainless steel 17-7 PH
9 ^[1]	Seat	Stainless steel, HT
10	Spiral wound gaskets	Stainless steel/graphite

Item	Part	Material
11 ^[2]	Screen	Stainless steel
12 ^[2]	Cap gasket	Monel®
13 ^[2]	Blow down seat	Stainless steel Type 416
14 ^[2]	Retaining ring	Stainless steel 17-7 PH
15 ^[2]	Blow down body	Stainless steel Type 416
16 ^[2]	O-ring	Silicone
17 ^[2]	Blow down valve	Stainless steel Type 416
18 ^[3]	Strainer cap	Stainless steel Type 416
19 ^[3]	Plug 3/8 NPT	Stainless steel
20 ^[3]	Blank strainer cap	Stainless steel
21 ^[3]	Socketweld strainer cap	Stainless steel

NOTES

1. Part of factory assembled renewal capsule.
2. Factory assembled blowdown valve renewal kit.
3. Optional strainer caps.

DIMENSIONS AND WEIGHTS

Trap size in. (DN)	Nominal dimensions, in. (mm)											Weight lb. (kg)	
	A	B	C	D	E	F	G	H	J	K	L	Series 711-UC	Series 721-UC
1/2 [15]	3 3/8 [86]	3 [76]	1 1/2 [38]	2 15/16 [75]	3 11/16 [94]	2 7/8 [73]	3 15/16 [100]	1 1/16 [27]	1/2 NPT	0.860 [21.8]	3/8 [9.5]	2 [0.9]	2 3/4 [1.25]
3/4 [20]	3 3/8 [86]	3 [76]	1 1/2 [38]	2 15/16 [75]	3 11/16 [94]	2 7/8 [73]	3 15/16 [100]	1 1/16 [27]	3/4 NPT	1.070 [27.2]	1/2 [12.7]	2 [0.9]	2 3/4 [1.25]
1 [25]	3 3/8 [86]	3 3/8 [86]	1 1/2 [38]	3 1/8 [79]	3 3/8 [98]	3 1/8 [78]	4 1/8 [105]	1 1/16 [27]	1 NPT	1.335 NPT	1/2 [12.7]	2 1/4 [1.1]	3 1/2 [1.6]

YARWAY REPAIRABLE DRIP AND TRACER STEAM TRAPS

SERIES 751/761, 711/721, 731/741, 500/546, 460/515/D3

SERIES 731/741 VARIABLE ORIFICE (PISTON)

The series 731/741 Unibody Plus variable orifice (piston) traps are designed for applications to 600 psi. The 'A' internals are designed for light load applications such as steam tracing and drip. The 'B', 'C' and 'E' internals are designed for the heavier process loads. The solid metal internals respond quickly to the presence of condensate, air and noncondensable gases. Two body styles and factory settings are available. Both the 741 and 731 bodies are straightway, accepting the same renewal capsules. The 741 body contains an integral wye strainer and blow-off valve. The factory settings are 'L' for operating pressures to 300 psi and 'H' to 600 psi.

Applicable codes and standards

Pressure ratings per ANSI/FCI-69-1. Performance testing per ANSI/ASME PTC-39.1. End connections per ANSI B.20.1 for threaded ends, per ANSI B16.11 for socket-welding ends.

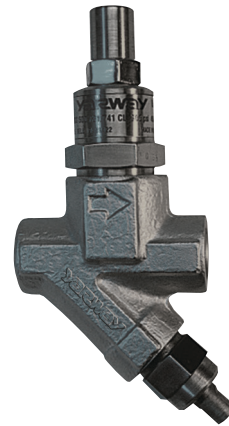

CONDENSATE CAPACITY NEAR STEAM TEMPERATURE (FOR STEAM TRAP SIZING)

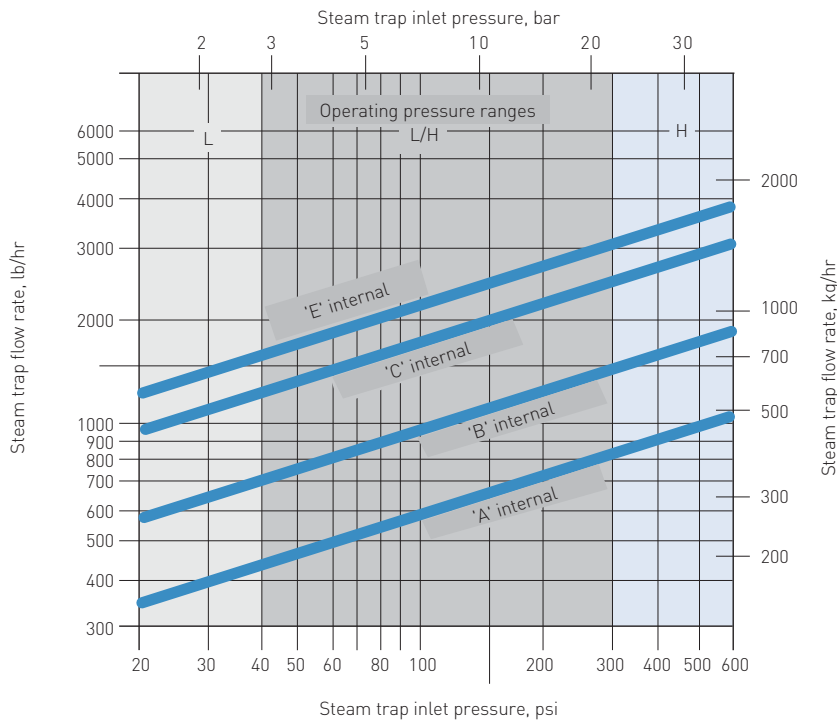

RATINGS

731L/741L

Design: ANSI Class 600
 Operating: 20-300 psi, 750°F
 (1.4-21 bar, 400°C)
 Back pressure: to 40% of inlet psia

731H/741H

Design: ANSI Class 600
 Operating: 40-600 psi, 750°F
 (21-41 bar, 400°C)
 Back pressure: to 25% of inlet psia

NOTE

For back pressure to 55% and/or operation to 10 psig, remove the split washer (Item 5)

HOW TO SPECIFY AND ORDER

Typical specification - trap shall be piston valve, impulse type. The body shall be forged low carbon (0.15 max. C) chrome-moly steel with threaded (or socketwelding) ends. The internals shall be stainless steel contained in a factory set and assembled renewal capsule.

Ordering - specify trap size, series number, internals, settings and end connections. Example: ¾" 741CL NPT.

DIMENSIONS AND WEIGHTS

Trap size in. (DN)	Nominal dimensions, in. (mm)										Weight lb. (kg)	
	A	B	C	D	E	F	G	H	J	K	Series 731	Series 741
½ (15)	3 ⁵ / ₃₂ (80)	1½ (38)	4 ¹ / ₁₆ (103)	2 ³ / ₈ (73)	3 ¹⁵ / ₁₆ (100)	4 ¹³ / ₁₆ (122)	0.860 (21.8)	¾ (9.5)	1 ¹ / ₁₆ (27)	½ NPT	2¼ (1.1)	2¾ (1.3)
¾ (20)	3 ³⁵ / ₆₄ (90)	1½ (38)	4 ³ / ₈ (111)	3¼ (83)	4 ⁵ / ₁₆ (110)	5 ¹ / ₈ (130)	1.070 (27.2)	½ (12.7)	1 ³ / ₁₆ (30)	¾ NPT	2¾ (1.3)	3½ (1.6)
1 (25)	3 ¹⁵ / ₁₆ (100)	1½ (38)	4 ³ / ₈ (111)	3 ³ / ₈ (86)	4 ¹ / ₁₆ (113)	5 ¹ / ₈ (130)	1.335 (33.9)	½ (12.7)	1 ³ / ₁₆ (30)	1 NPT	3 (1.4)	4 (1.8)

YARWAY REPAIRABLE DRIP AND TRACER STEAM TRAPS

SERIES 751/761, 711/721, 731/741, 500/546, 460/515/D3

SERIES 731/741 VARIABLE ORIFICE (PISTON)

SERIES 731

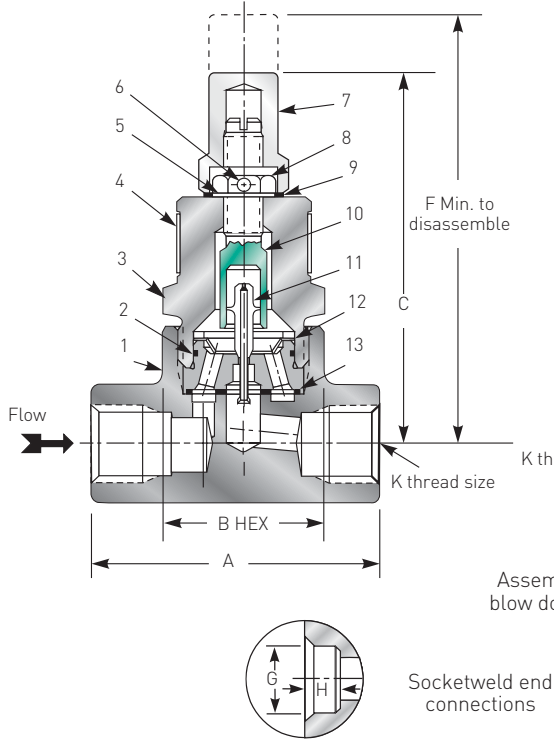

SERIES 741

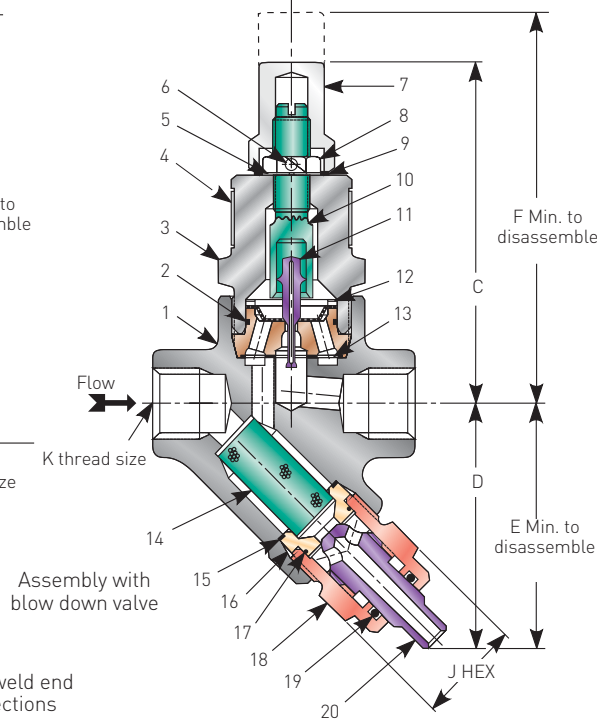

PARTS AND MATERIALS

Item	Part	Material
1	Body	Chrome Moly, 0.15%C ASME SA-182 Gr. F-11
2 ^[1]	Retaining ring	17-7 PH stainless steel
3 ^[1]	Bonnet	Stainless steel
4 ^[1]	Nameplate	Stainless steel
5 ^[1]	Split washer	Brass
6 ^[1]	Lock pin	Brass
7 ^[1]	Cap nut	Stainless steel 400
8 ^[1]	Lock nut	Stainless steel
9 ^[1]	Cap gasket	Monel®
10 ^[1]	Control cylinder	Stainless steel
11 ^[1]	Valve	Stainless steel
12 ^[1]	Valve seat	Stainless steel Type 414HT
13 ^[1]	Seat gasket	Clad non-asbestos
14	Screen	Stainless steel 0.020 perf.
15 ^[2]	Cap gasket	Monel®
16 ^[2]	Blowdown seat	416 stainless steel
17 ^[2]	Retaining ring	17-7 PH stainless steel
18 ^[2]	Blowdown body	416 stainless steel
19 ^[2]	O-ring	Silicone
20 ^[2]	Blowdown valve	416 stainless steel
21 ^[3]	Strainer cap	416 stainless steel
22 ^[3]	Plug 3/8 NPT	Carbon steel A-105
23 ^[3]	Blank strainer cap	Stainless steel

NOTES

1. Factory assembled renewal trap capsule.
2. Factory assembled blowdown valve renewal kit.
3. Optional strainer caps.

YARWAY REPAIRABLE DRIP AND TRACER STEAM TRAPS

SERIES 751/761, 711/721, 731/741, 500/546, 460/515/D3

SERIES C-500 AND 546 - UP TO 4500 psig HIGH PRESSURE STEAM TRAPS

Designed for condensate removal in high pressure industrial, electric utility and marine systems, Yarway supplies a range of compact and easily maintained thermodynamic traps. Substantially smaller than comparable mechanical traps for high pressure application, the Yarway traps occupy minimal space in the piping. Heavy duty structural support is not required. Operation involves only a single moving part. Ease of replacement of working internals also simplifies changing of capacity of any one trap merely by shifting to a differently rated set of internals.

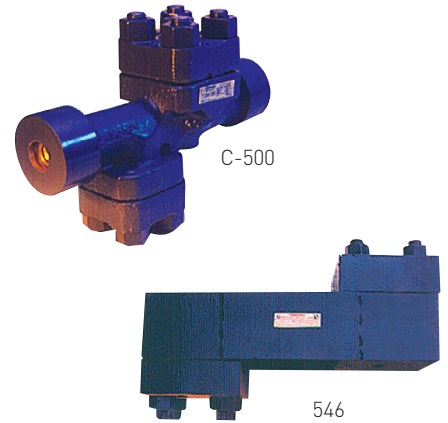

PRESSURE AND TEMPERATURE RATINGS

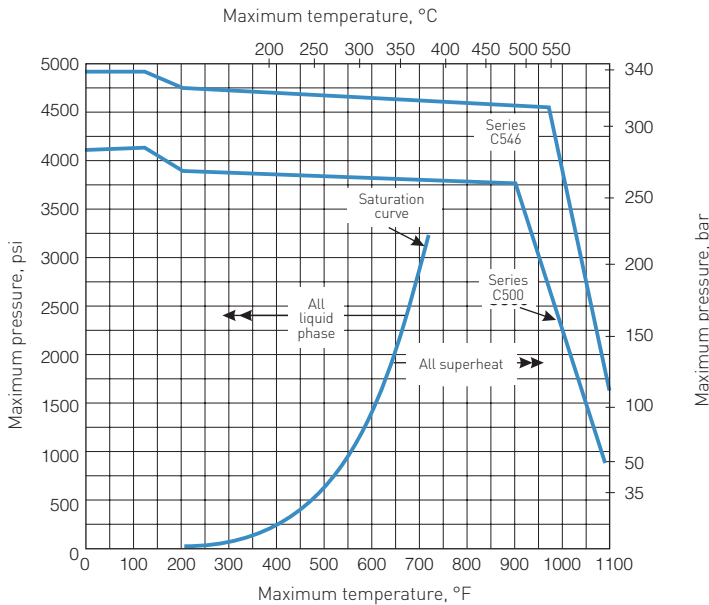

APPLICABLE CODES AND STANDARDS

Performance testing per ANSI/ASME PTC-39.1. End connections per ANSI B16.11 for socket-welding ends.

HOW TO SPECIFY AND ORDER

Typical specification - the trap shall be Piston Valve Quick Change Trim Integral Strainer Impulse® Trap. and shall require neither bucket, bellows nor bimetallic element for operation.

Ordering

1. Designate size of end connections (weights and dimensions table);
2. Designate figure number;
3. Designate trap internals (capacities curve);
4. Designate 'R' for commercial. Example: 1" 546 ASWR;
5. Specify if 1/2" socket-weld strainer blowdown is required.

* Back pressure: to 25% of inlet psia

CONDENSATE CAPACITY NEAR STEAM TEMPERATURE (FOR STEAM TRAP SIZING)

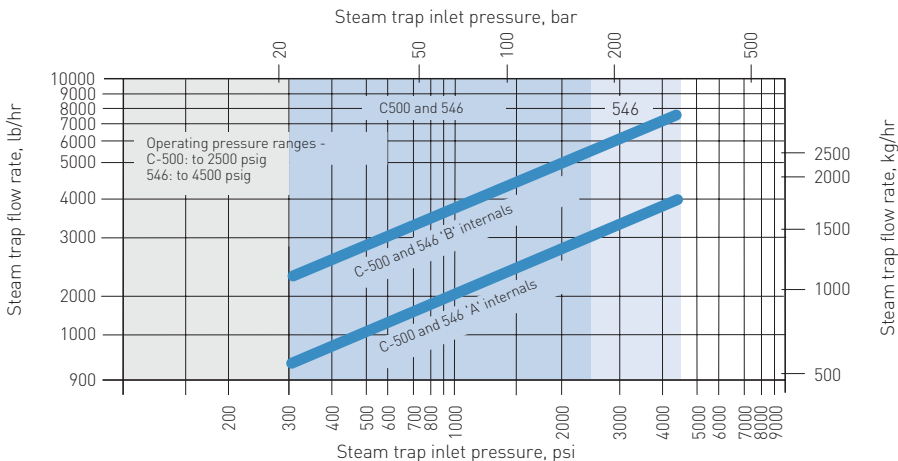

YARWAY REPAIRABLE DRIP AND TRACER STEAM TRAPS

SERIES 751/761, 711/721, 731/741, 500/546, 460/515/D3

SERIES C-500 AND 546 - UP TO 4500 psig HIGH PRESSURE STEAM TRAPS

SERIES C-500

SERIES 546

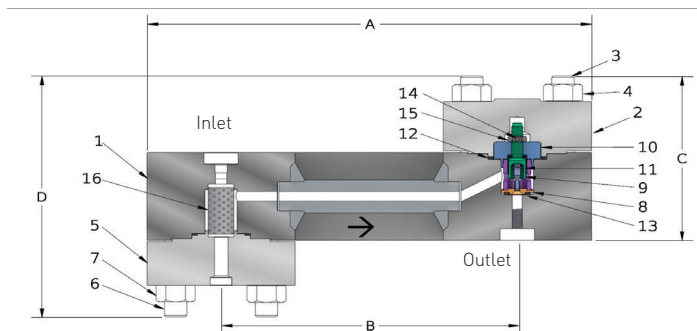
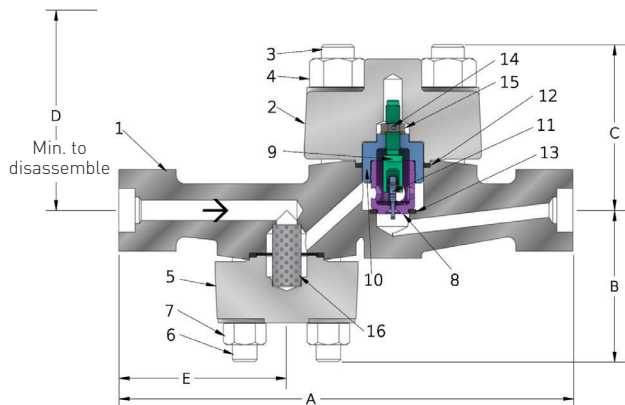

PARTS AND MATERIALS

Item	Part	Material specification	
		C-500 (Class 2500)	546 (Class 4500)
1	Body	Cast chrome moly ASTM A-217 GR. WC9	Forged chrome moly ASTM A-182 F-22
2	Trap bonnet	Cast chrome moly ASTM A-217 GR. WC9	Forged chrome moly ASTM A-182 F-22
3	Trap bonnet stud	Alloy steel ASME SA193 B16	Alloy steel ASME SA479 GR. XM-19
4	Trap bonnet nut	Alloy steel ASME SA194 GR. 16	Alloy steel ASME SA194 GR. 16
5	Strainer bonnet	Cast chrome moly ASTM A-217 GR. WC9	Forged chrome moly ASTM A-182 F-22
6	Strainer bonnet stud	Alloy steel ASME SA479 GR. XM-19	Alloy steel ASME SA479 GR. XM-19
7	Strainer bonnet nut	Alloy steel ASME SA194 GR. 16	Alloy steel ASTM A-194 GR. 4
8 ⁽¹⁾	Seat	Stainless steel AISI series 400 heat treated	Stainless steel AISI series 400 heat treated
9 ⁽¹⁾	Control cylinder	Stainless steel heat treated	Stainless steel heat treated
10 ⁽¹⁾	Cylinder adapter	Stainless steel AISI series 400	Stainless steel AISI series 400
11 ⁽¹⁾	Valve	Stainless steel AISI series 400 heat treated	Stainless steel AISI series 400 heat treated
12 ⁽¹⁾	Bonnet gasket	Spiral wound non-asbestos	Spiral wound non-asbestos
13 ⁽¹⁾	Seat gasket	Spiral wound non-asbestos	Spiral wound non-asbestos
14 ⁽¹⁾	Lock pin	Monel®	Monel®
15 ⁽¹⁾	Lock nut	Stainless steel AISI series 400	Stainless steel AISI series 400
16 ⁽¹⁾	Screen	Stainless steel AISI series 300, 0.020 Perf.	Stainless steel AISI series 300, 0.020 Perf.

DIMENSIONS AND WEIGHTS

Series	Size in. (DN)	Nominal dimensions, in. (mm)							Weight lb. (kg)
		A	B	C	D	E ⁽²⁾	G	H	
C-500	½ (15)	13¾ (352)	4¾ (117)	5½ (130)	8½ (216)	5½ (130)	0.860 (21.7)	¾ (9.5)	40 (18)
	¾ (20)	13¾ (352)	4¾ (117)	5½ (130)	8½ (216)	5½ (130)	1.070 (27.0)	½ (12.5)	40 (18)
	1 (25)	13¾ (352)	4¾ (117)	5½ (130)	8½ (216)	5½ (130)	1.335 (33.8)	½ (12.5)	40 (18)
546	1 (25)	17¼ (438)	11½ (292)	7½ (191)	11 (279)	N/A	1.335 (33.8)	½ (12.5)	122 (55)

NOTES

- Supplied in a renewal kit.
- ½" socketweld blow-off optional

YARWAY REPAIRABLE DRIP AND TRACER STEAM TRAPS

SERIES 751/761, 711/721, 731/741, 500/546, 460/515/D3

SERIES 460 AND 515 TO 1500 psig HIGH PRESSURE STEAM TRAPS

The Yarway high pressure integral strainer trap is designed with Quick Change Trim (QCT) using the proven variable orifice (piston) internals. These traps are designed for a variety of high pressure applications found in utility, industrial and marine service. Typical applications include steam main drip, turbine drain, soot blower, steam separator, fuel, water, air heater and preheater, protection of expansion joints or loops, and control valve.

The small, lightweight design and broad range of operating pressures are among the many advantages when compared to mechanical traps of the same pressure rating. In addition, the QCT design is renewable in-line with factory set and assembled internals without the need to disturb the piping.

Applicable codes and standards

Pressure ratings per ANSI/FCI-69-1. Performance testing per ANSI/ASME PTC-39.1. End connections per ANSI B16.11.

SERIES 460

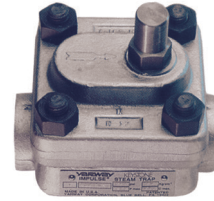

SERIES 515

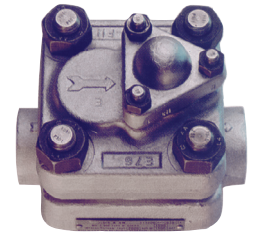

SHELL PRESSURE/TEMPERATURE RATINGS

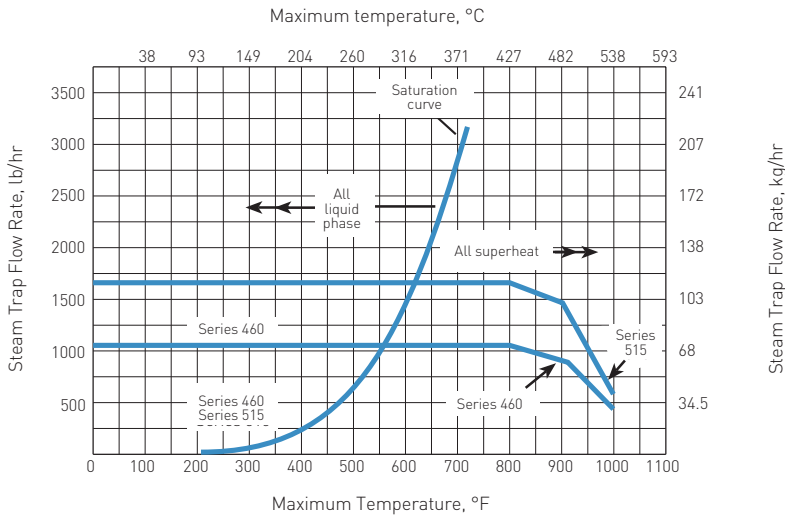

HOW TO SPECIFY AND ORDER

Typical specifications - the trap shall be Variable Orifice Piston Valve, Quick Change Trim, Integral Strainer, Impulse® Trap and shall require neither bucket, bellows nor bimetallic element for operation (option - 1/2" socketwelding ends).

Ordering

1. Designate size of end connections (weights and dimensions table).
2. Designate figure number (selector guide).
3. Designate trap internals (capacities curve and selector guide).

Back pressure ratings

Back pressure to 25% as factory set for series 460 and 515; back pressure to 55% for series 460 with field removal of split washer. Back pressures are based on absolute pressure.

OPERATING PRESSURE RANGES VS. CONDENSATE CAPACITY NEAR STEAM TEMPERATURE (for steam trap sizing)

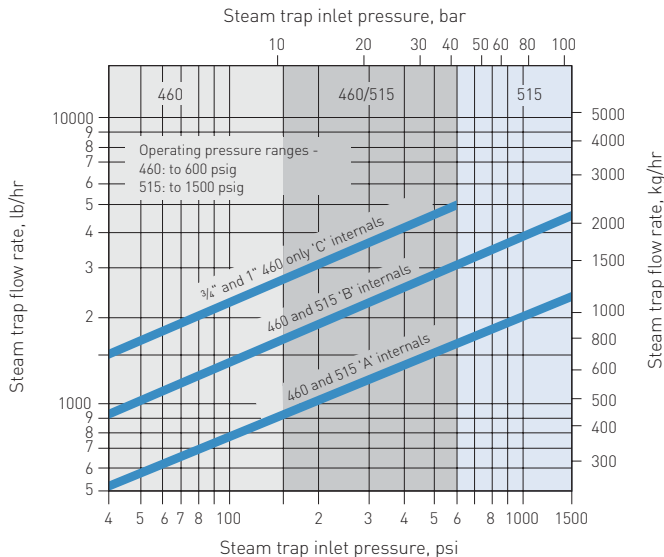

How to interpret the curves

First, use the shell pressure/temperature curves to confirm that the trap selected is suitable for the design maximum pressure and temperature of the application. Then, select the trap on the basis of operating pressure. Finally, select the trap internals that will provide the required discharge capacity at the operating pressure.

YARWAY REPAIRABLE DRIP AND TRACER STEAM TRAPS

SERIES 751/761, 711/721, 731/741, 500/546, 460/515/D3

SERIES 460 AND 515 TO 1500 psig HIGH PRESSURE STEAM TRAPS

SERIES 460

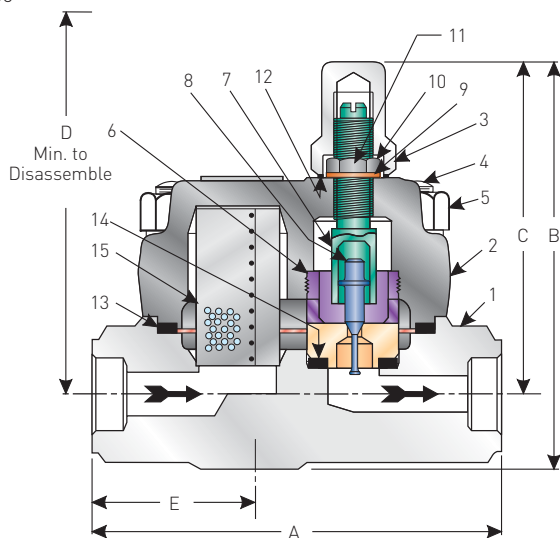

SERIES 515

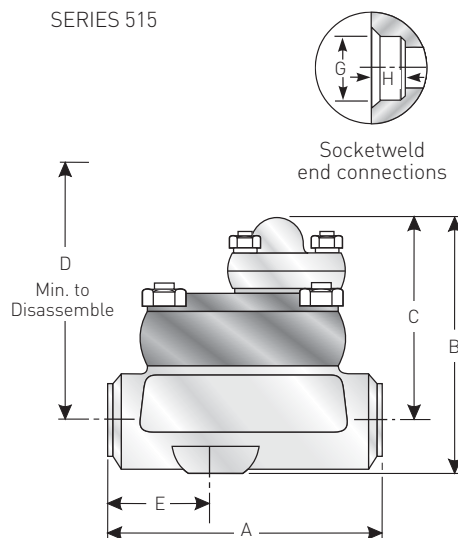

PARTS AND MATERIALS

Part No	Part	Material specification	
		460 (Class 600)	515 (Class 1500)
1	Body	Forged chrome moly ASME SA-182 F-11, 15 Max. C	Forged chrome moly ASME SA-182 F-11, 15 Max. C
2	Trap bonnet	Forged chrome moly ASME SA-182 F-11, 15 Max. C	Forged chrome moly ASME SA-182 F-11, 15 Max. C
3	Cap	Stainless steel series 400	Forged chrome moly ASME SA-182 F-11
4	Studs	Steel ASME SA-193 B-16	Steel ASME SA-193 B-16
5	Nuts	Steel ASTM A-194 GR. 7	Steel ASTM A-194 Gr. 7
6	Seat	Stainless steel AISI series 400 heat treated	Stainless steel AISI series 400 heat treated
7 ⁽¹⁾	Control cylinder	Stainless steel AISI series 400 mod.	Stainless steel 17-4 PH heat treated
8 ⁽¹⁾	Valve	Stainless steel AISI series 400 heat treated	Stainless steel AISI series 400 heat treated
9 ⁽¹⁾	Split washer	Brass	Monel [®]
10 ⁽¹⁾	Lock nut	Stainless steel AISI series 400	Stainless steel AISI series 400
11 ⁽¹⁾	Lock pin	Brass	Monel [®]
12 ⁽¹⁾	Cap gasket	Monel [®]	Inconel [®] , spiral wound non-asbestos
13 ⁽¹⁾	Bonnet gasket	Inconel [®] , spiral wound non-asbestos	Inconel [®] , spiral wound non-asbestos
14 ⁽¹⁾	Seat gasket	Inconel [®] , spiral wound non-asbestos	Inconel [®] , spiral wound non-asbestos
15 ⁽¹⁾	Screen	Stainless steel AISI series 300, 0.020" perf.	Stainless steel AISI series 300, 0.020" perf.

DIMENSIONS AND WEIGHTS

Series	Size in. (DN)	Nominal dimensions, in. (mm)							Weight lb. (kg)
		A	B	C	D	E ⁽²⁾	G	H	
460	1/2 (15)	4 ¹³ / ₁₆ (122.2)	5 (127.0)	4 (101.6)	5 ⁵ / ₁₆ (134.9)	1 ⁷ / ₈ (47.6)	0.860 (21.8)	3/8 (10.0)	10 1/2 (4.76)
	3/4 (20)	4 ¹³ / ₁₆ (122.2)	5 (127.0)	4 (101.6)	5 ⁵ / ₁₆ (134.9)	1 ⁷ / ₈ (47.6)	1.070 (27.0)	1/2 (12.5)	10 1/2 (4.76)
	1 (25)	4 ¹³ / ₁₆ (122.2)	5 (127.0)	4 (101.6)	5 ⁵ / ₁₆ (134.9)	1 ⁷ / ₈ (47.6)	1.335 (33.9)	1/2 (12.5)	10 1/2 (4.76)
515	1/2 (15)	5 1/2 (139.7)	5 1/2 (139.7)	4 1/2 (114.3)	7 1/2 (181.0)	2 ⁷ / ₃₂ (56.4)	0.860 (21.8)	3/8 (10.0)	16 (7.26)
	3/4 (20)	5 1/2 (139.7)	5 1/2 (139.7)	4 1/2 (114.3)	7 1/2 (190.5)	2 ⁷ / ₃₂ (56.4)	1.070 (27.2)	1/2 (12.5)	16 (7.26)
	1 (25)	5 1/2 (139.7)	5 1/2 (139.7)	4 1/2 (114.3)	7 1/2 (190.5)	2 ⁷ / ₃₂ (56.4)	1.335 (33.9)	1/2 (12.5)	16 (7.26)

NOTES

- Supplied in a renewal kit.
- 1/2" socketweld blow-off optional.

YARWAY REPAIRABLE DRIP AND TRACER STEAM TRAPS

SERIES 751/761, 711/721, 731/741, 500/546, 460/515/D3

SERIES 460D3 AND 515D3 TO 1500 PSIG HIGH PRESSURE STEAM TRAPS

The Yarway high pressure integral strainer trap is designed with a removable capsule incorporating high pressure disc technology. These traps are designed for a variety of high pressure applications found in utility, industrial and marine service. Typical applications include steam tracing, steam main drip and turbine drain.

The small, lightweight design and broad range of operating pressures are among the many advantages when compared to mechanical traps of the same pressure rating. In addition, the quick change capsule design is renewable in-line with factory assembled internals without the need to disturb the piping.



SHELL PRESSURE/TEMPERATURE RATINGS

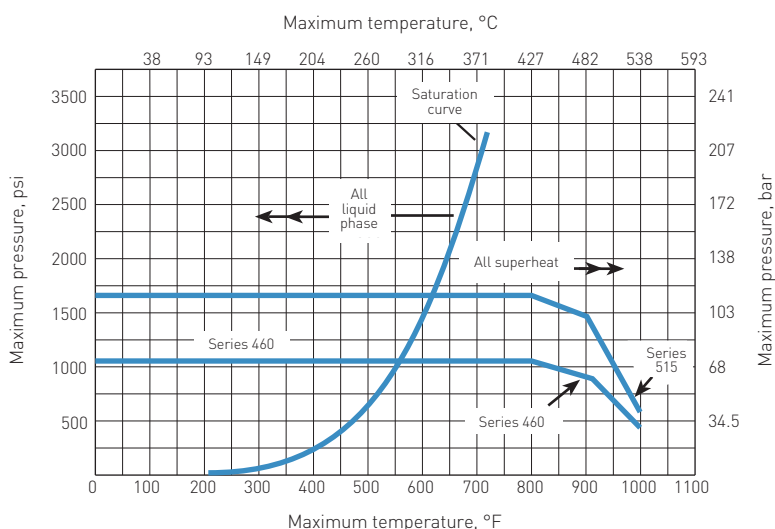

OPERATING PRESSURE RANGES VS. CONDENSATE CAPACITY NEAR STEAM TEMPERATURE (for steam trap sizing)

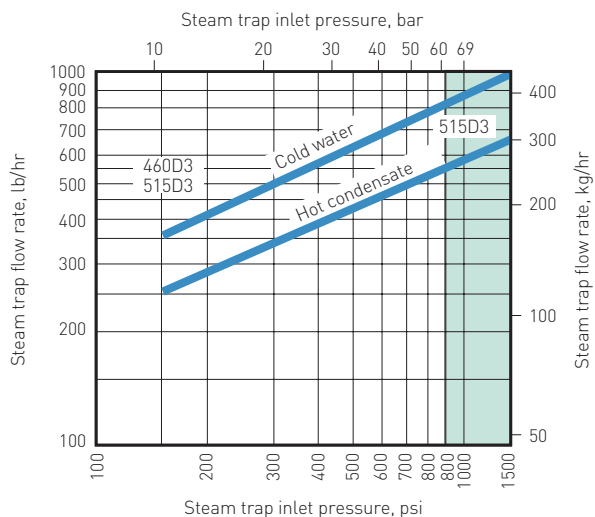

APPLICABLE CODES AND STANDARDS

Pressure ratings per ANSI/FCI-69-1.
Performance testing per ANSI/ASME PTC-39.1.
End connections per ANSI B16.11.

Trap operating conditions

Maximum operating pressure: 460D3 - 900 psig
515D3 - 1500 psig

Minimum operating pressure: 150 psig

Maximum operating temperature: 900°F

HOW TO SPECIFY AND ORDER

Typical specifications - the trap shall be an integral strainer disc trap with removable capsule, and shall require neither bucket, bellows, nor bimetallic element for operation.

Ordering

1. Designate size of end connections (weights and dimensions table).
2. Designate figure number (selector guide).
3. Designate 'R' for commercial. Example: ¾" 460D3SWR.

Back pressure ratings

Back pressure to 80%. Back pressures are based on absolute pressure.

How to interpret the curves

First, use the shell pressure/temperature curves to confirm that the trap selected is suitable for the design maximum pressure and temperature of the application. Then, select the trap on the basis of operating pressure.

YARWAY REPAIRABLE DRIP AND TRACER STEAM TRAPS

SERIES 751/761, 711/721, 731/741, 500/546, 460/515/D3

SERIES 460D3 AND 515D3 TO 1500 psig HIGH PRESSURE STEAM TRAPS

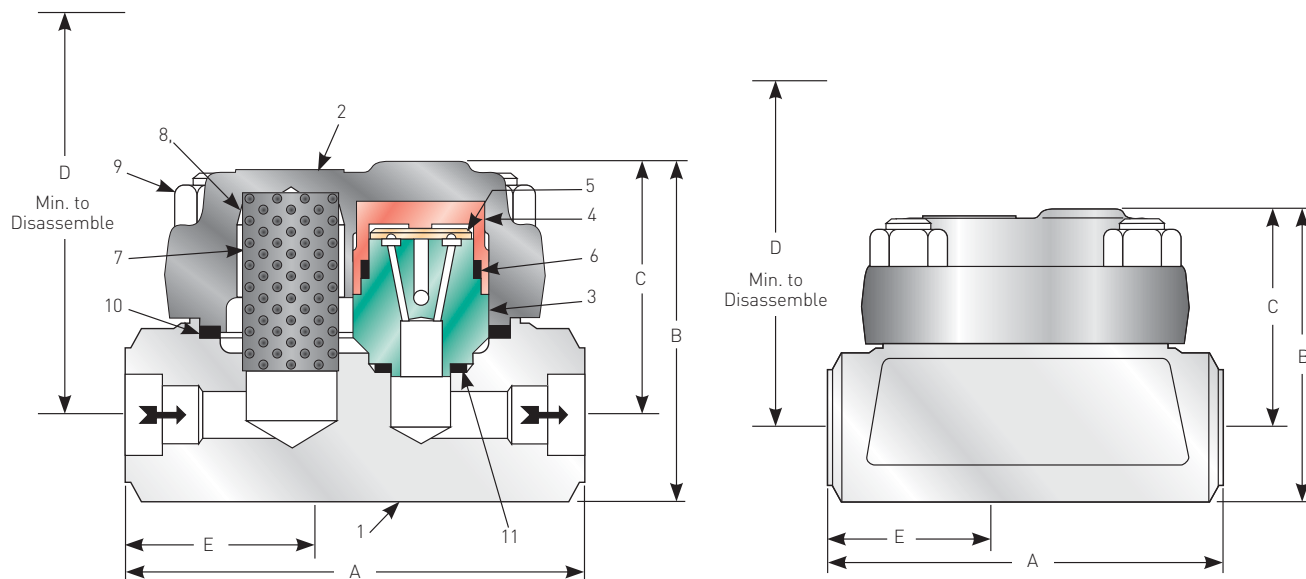

PARTS AND MATERIALS

Part No	Part	Material specification	
		460D3 (Class 600)	515D3 (Class 1500)
1	Body	Forged chrome moly ASME SA-182 F-11, 15 Max. C	Forged chrome moly ASME SA-182 F-11, 15 Max. C
2	Trap bonnet	Forged chrome moly ASME SA-182 F-11, 15 Max. C	Forged chrome moly ASME SA-182 F-11, 15 Max. C
3 ^[1,2]	Seat	Stainless steel AISI series 400 heat treated	Stainless steel AISI series 400 heat treated
4 ^[1,2]	Cap	Stainless steel AISI series 400 heat treated	Stainless steel AISI series 400 heat treated
5 ^[1,2]	Disc	Stainless steel AISI series 400 heat treated	Stainless steel AISI series 400 heat treated
6 ^[1,2]	Cap gasket	Grafoil®	Grafoil®, spiral wound non-asbestos
7 ^[1]	Screen	Stainless steel AISI series 300, 0.020" perf.	Stainless steel AISI series 300, 0.020" perf.
8 ^[1]	Studs	Steel ASME SA-193 B-16	Steel ASME SA-193 B-16
9 ^[1]	Nuts	Steel ASTM A-194 B-7	Steel ASTM A-194 B-7
10 ^[1]	Bonnet gasket	Inconel®/Graphite spiral wound non-asbestos	Inconel®/Graphite spiral wound non-asbestos
11 ^[1]	Seat gasket	Inconel®/Graphite spiral wound non-asbestos	Inconel®/Graphite spiral wound non-asbestos

DIMENSIONS AND WEIGHTS

Series	Size in. (DN)	Nominal dimensions, in. (mm)							Weight lb. (kg)
		A	B	C	D	E ³	G	H	
460D3	½ (15)	4 ¹³ / ₁₆ (122.2)	4 ⁹ / ₁₆ (115.9)	2 ⁷ / ₁₆ (65.1)	5 ⁵ / ₁₆ (135)	1 ⁷ / ₈ (47.6)	0.860 (21.8)	¾ (10.0)	10½ (4.76)
	¾ (20)	4 ¹³ / ₁₆ (122.2)	4 ⁹ / ₁₆ (115.9)	2 ⁷ / ₁₆ (65.1)	5 ⁵ / ₁₆ (135)	1 ⁷ / ₈ (47.6)	1.070 (27.2)	½ (12.5)	10½ (4.76)
	1 (25)	4 ¹³ / ₁₆ (122.2)	4 ⁹ / ₁₆ (115.9)	2 ⁷ / ₁₆ (68.1)	5 ⁵ / ₁₆ (135)	1 ⁷ / ₈ (47.6)	1.335 (33.9)	½ (12.5)	10½ (4.76)
515D3	½ (15)	5½ (139.7)	4 ¹ / ₈ (104.8)	3 ¹ / ₈ (79.4)	5¾ (146)	2 ⁷ / ₃₂ (56.4)	0.860 (21.8)	¾ (10.0)	16 (7.26)
	¾ (20)	5½ (139.7)	4 ¹ / ₈ (104.8)	3 ¹ / ₈ (79.4)	5¾ (146)	2 ⁷ / ₃₂ (56.4)	1.070 (27.2)	½ (12.5)	16 (7.26)
	1 (25)	5½ (139.7)	4 ¹ / ₈ (104.8)	3 ¹ / ₈ (79.4)	5¾ (146)	2 ⁷ / ₃₂ (56.4)	1.335 (33.9)	½ (12.5)	16 (7.26)

NOTES

1. Supplied in a renewal kit.
2. Supplied as a preassembled capsule.
3. ½" socketweld blow-off optional.

Neither Emerson, Emerson Automation Solutions, nor any of their affiliated entities assumes responsibility for the selection, use or maintenance of any product. Responsibility for proper selection, use, and maintenance of any product remains solely with the purchaser and end user.

Yarway is a mark owned by one of the companies in the Emerson Automation Solutions business unit of Emerson Electric Co. Emerson Automation Solutions, Emerson and the Emerson logo are trademarks and service marks of Emerson Electric Co. All other marks are the property of their respective owners.

The contents of this publication are presented for informational purposes only, and while every effort has been made to ensure their accuracy, they are not to be construed as warranties or guarantees, express or implied, regarding the products or services described herein or their use or applicability. All sales are governed by our terms and conditions, which are available upon request. We reserve the right to modify or improve the designs or specifications of such products at any time without notice.

Emerson.com/FinalControl