



PRESSURE REDUCING VALVES

Class GP Regulators

TABLE OF CONTENTS

SECTION I — INSTALLATION2
SECTION II —OPERATION3-4
SECTION III — MAINTENANCE5-6
GPK-1T, GPK-2TC, GPK-2T AND GPK-4T7-8
Parts List9-30

ILLUSTRATION INDEX

DRAWING, DIMENSIONS, TYPICAL INSTALLATIONS AND MISCELLANEOUS DATA

Figure 1 - Valve Installations2
Figure 2 - Valve Installations2
Figure 4 - GP Type Control Valve5
Figure 6 - Removing Seat Ring6
Figure 7 - Air/Gas Service Main Valve Complete7
Drawing - Cast/Ductile Iron GP9
Drawing - GPK-V Units15
Drawing - Hand Operating Device16
Drawing - Cast Bronze GP17
Drawing - Direct Diaphragm20
Drawing - GPAS-122
Drawing - GPS(S)-1(S)23

SECTION I — INSTALLATION

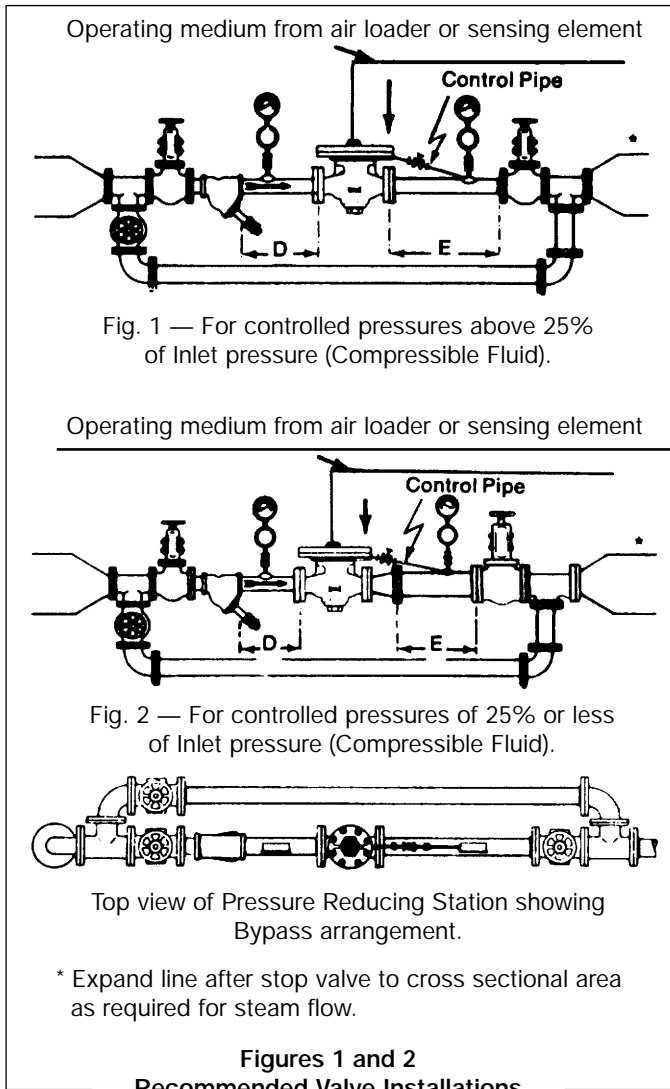

Piping Details

Recommended Straight Run Piping Dimensions inlet and

VALVE SIZE	DIMENSIONS	
	D	E
1/2" to 1-1/2"	1'6" to 5'	4' to 5'
2" to 4"	3' to 5'	4' to 8'

outlet — All Types and Pressures

Valve Position

Install valve upright in the highest horizontal line of piping, in an accessible location and with the arrow on the side of the body in the direction of fluid flow.

NOTE: STOP VALVE IS NECESSARY WHEN SENSING LINE IS LOCATED DOWN STREAM OF OUTLET STOP VALVE.

Problem Preventing Procedure

1. Provide space above, below and around the valve for removal of parts during maintenance.
2. Blow or flush out the pipe lines thoroughly before installing the valve.
3. Remove raised faces of iron or steel line flanges to which bronze valves are to be bolted. Make outside diameter of gaskets the same as flanges; inside diameter is 1/4" larger than the bore of the flanges.
4. Do not use red lead or cement in making up joints. In threaded valves use pipe compound sparingly on male threads only.
5. **STRAINER** — Protect the valve and following equipment with a Self-Cleaning Strainer.
6. Install stop valves and gages in inlet and outlet lines to provide a means for checking adjustment and operation of the equipment.
7. In steam service, insulate all piping before and after the valve to minimize condensation. Provide proper inlet drainage to prevent water hammer or erosion in the equipment.
8. Adhere to good piping practice. Install a bypass around the valve.

Control Pipe — All Pressures

Connect 3/8" control pipe (having I.D. equivalent to 40 schedule pipe) with stop valve, union and pressure gage (as shown in Figures 1 and 2) from threaded connection in main body of valve to section of outlet piping **before outlet stop valve**. **Slop control pipe downward to outlet piping to prevent water pockets.**

Important — Make control pipe connection in expanded outlet piping at a point at least 24" downstream from the end of the expander and not within 18" to 24" of the outlet stop valve, any elbow or other flow direction changing fitting. Control pipe length should be held to approximately 3'. Connect control pipe to side of outlet pipe if necessary to obtain proper slope.

Recommended outlet piping for valves controlling compressible fluids at values of 25% or less of inlet pressure;

Expand outlet pipe (**E Dimension**) to twice the valve size. Use **tapered** expander — 15°/20° on included angle.

Note: Further expansion of low pressure outlet piping beyond the outlet stop valve has no effect on operation of this valve.

SECTION II — OPERATION

For installation, adjustment of loading device and operating details, consult the proper instructions pertaining to the particular type of loading, sensing or other operating device.

Overall Valve Dimensions

For overall valve dimensions — face-to-face, height, etc., — consult the drawing which applies to the valve in use.

Principle of Operation

The control valves are operated by means of an airloading force delivered by a loading valve, temperature pilot or similar device which delivers an air signal to the diaphragm of the regulator. Figure 3 shows the loading pressures required for various valve sizes and pressure drops. Diaphragm pressure quoted, for any particular size or pressure drop, is the pressure required on the diaphragm to open the valve under the existing conditions. Beyond this value an ratio of 1:1 delivered steam pressure to additional air loading pressure will be obtained. The valve will then maintain the controlled pressure accurately and in direct relation to the loading pressure value above that which is necessary to open the valve.

Operation of GP Type Control Valves In conjunction With Air Loaders

Important: DO NOT apply air-loading force to diaphragm of control valve until inlet stop valve is fully opened with full pressure to inlet of the control valve.

Starting Up:

1. Open inlet stop valve.
2. Close outlet stop valve.
3. Dispose of condensation, dirt, etc., by opening the strainer blow-off valve.
4. Crack outlet stop valve to permit slight flow when adjusting the control valve.
5. Slowly supply loading pressure to control valve diaphragm until the valve begins to open. Gradually increase loading pressure until desired downstream controlled pressure is obtained.
6. Slowly open outlet stop valve.
7. To increase controlled pressure, increase loading pressure. To decrease controlled pressure, decrease loading pressure.

Shutting down:

To turn steam off, relieve loading pressure from diaphragm of the control valve and close inlet and outlet stop valves.

SECTION II — OPERATION (CON'T)

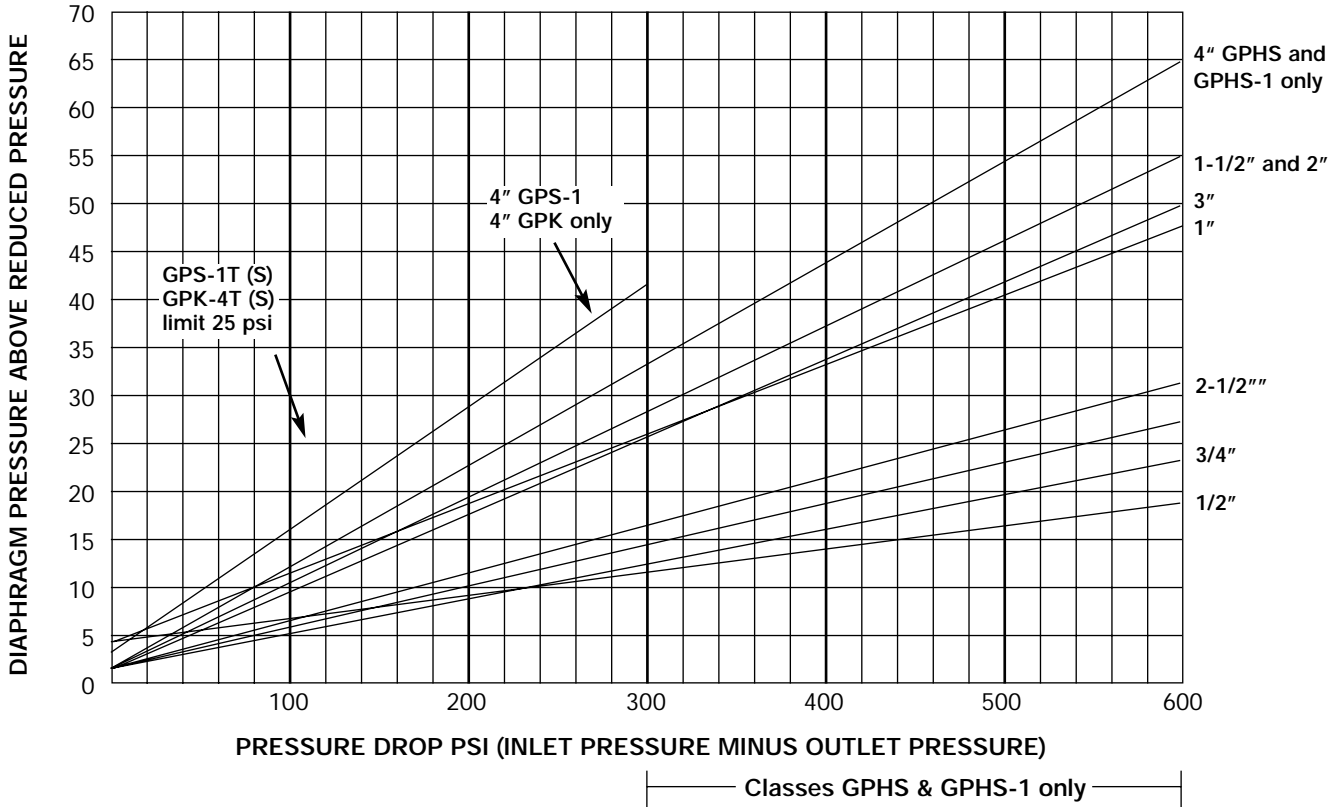

CLASS	MAX. INLET* & MAX. ΔP
GPK	250
GPB	300
GPS	300
GPS-1	300
GPHS	600
GPHS-1	600
GPAK	400
GPAS-1	400

*Subject to valve body limitations.

The above curves indicate the loading pressures above the outlet pressure require for each size class GPK, GPAK,

GPB, GPS, GPHS, GPS-1, GPHS-1, and variants for all pressure differentials across the valves.

EXAMPLE: If a 3" GPB reducing valve is required to reduce steam from 300 psig to 20 psig, 44 psig air loading is required. This is determined as follows: Enter the chart at 280 psi pressure drop and read up to the 3" size. Read across to 24 psi, which must be added to the outlet pressure to determine the required loading pressure.

NOTE: Maximum diaphragm joint pressure is 300 psig. Loading pressure (reduced pressure plus diaphragm pressure above reduced pressure must not exceed 300 psig.

SECTION III — MAINTENANCE

Leslie control valves may be dismantled without removal from pipeline when maintenance checks are desired.

Play Safe! Use Only Genuine Leslie Replacement Parts

All Leslie control valves are made of high quality materials, are time-tested and backed by more than a half century of knowhow. Machining is done by expert craftsmen and each valve is inspected and service-tested before shipment to you.

Use of other than GENUINE LESLIE PARTS may impair their ability to work properly. DO NOT change any dimensions except as noted in these instructions. To assure long life, preservation of parts interchangeability and low maintenance costs, use only standard LESLIE PARTS.

CHECK NAMEPLATE FOR PROPER CLASS AND WRITE FOR APPLICABLE DRAWINGS.

Dismantling

1. Shut off air supply. Disconnect loading line to release air pressure from diaphragm area.
2. Close stop valves on inlet and outlet sides of control valve and open strainer blowdown valve to vent trapped fluid.
3. Loosen and remove bottom cap. Gasket, main valve spring and main valve will follow.
4. Do not remove seat ring unless remachining or replacement is necessary. If removal is necessary, see Figure 6 with accompanying instructions.
5. To examine diaphragm (two leaves) and main valve guide or to clean diaphragm area, remove diaphragm cover bolts/nuts, diaphragm and diaphragm disc. To take out diaphragm disc, form two hooks of 1/16" diameter wire and lift out disc.

Cleaning, Replacing or Repairing Parts

Clean all parts with kerosene or other approved solvent and check as follows:

1. Examine main valve, seat ring and main valve guide. Remove any encrusted material with crocus cloth.
2. FOR ALL-METAL SEATS ONLY: If main valve or seat ring seating surfaces are cut or scored, regrind with 600 grit grinding compound. Remove all trace of grinding compound before reassembling.

NOTE: If main valve, seat ring or both must be remachined due to damage to seating surfaces, in order to maintain correct diaphragm disc to diaphragm seat dimension, it will be necessary to shorten the main valve. To do this, remove from the top of the main valve stem (diaphragm disc end) an amount of metal equal to the amount (dimensional thickness) removed from the main valve and or the seat ring.

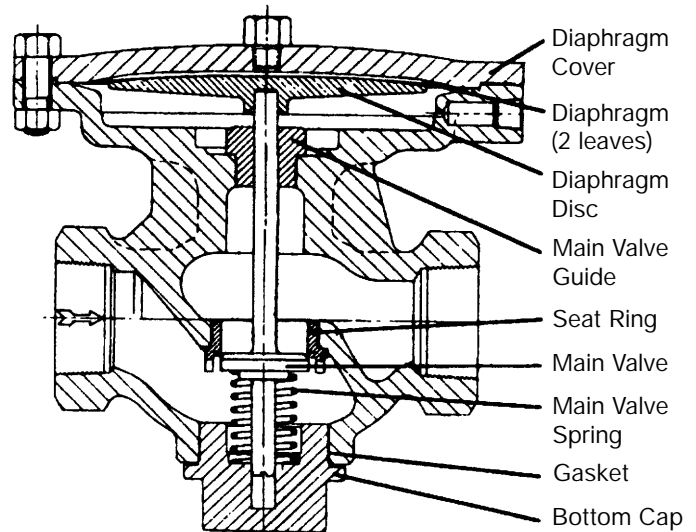

Figure 4 — GP Type Control Valve

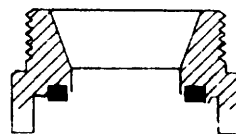

Figure 5 — Soft Seat Ring

Seat Ring Wrench -
Insert Bar Through Hole

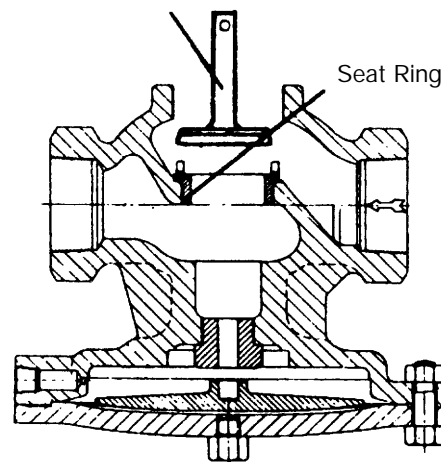

Figure 6 — Removing Seat Ring

Use 600 grit compound, lap the main valve into the seat. When relapping main valves in sizes 2-1/2" larger, take off diaphragm cover and remove diaphragms so that their spring action will not interfere with the lapping operations.

Replacing Seat Rings

To remove seat rings, use the special wrench which is available on request. See Figure 6.

Position seat ring wrench and socket wrench as shown in Figure 6. Hold tightly against seat ring. Tap handle of socket with hammer to loosen seat ring. Then unscrew seat ring.

To Install Seat Ring

1. Carefully clean threads and joint contact surfaces on seat ring and in the valve body.
2. Make sure joint surfaces are undamaged.
3. Use a light coating of Never-Seez or similar lubricant on the first two threads only of seat ring. Screw seat ring into valve body threads and pull up tight with wrench.
4. Tap handle of socket wrench with hammer to lock seat ring in place.

Hard Seats Only:

5. Lap in main valve and seat ring carefully. Use very fine lapping compound.

Reassembly

1. Do not use graphite or compound on joints.
2. Place main valve, main valve spring and gasket on bottom cap. Assemble bottom cap part way (enough to hold in place) on main body.
3. Place diaphragm disc on main valve with guide end over stem end of the main valve.
4. Put diaphragm leaves together, matching convolutions as closely as possible, and position them carefully in main body above diaphragm disc.
5. Assemble diaphragm cover and bolts/nuts to main body. Snug up bolts alternately and evenly across diaphragm cover. Then tighten firmly. Tighten bottom cap. Reconnect air-loading line.

Replacing Main Valve Disc Air or Gas Service Valves

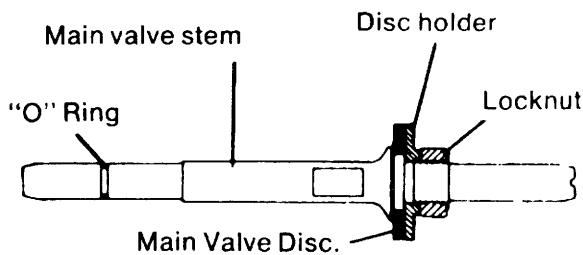

Figure 7 — Air/Gas Service
Main Valve Complete

Hold locknut rigidly. Use wrench on flats of stem to loosen stem. Disassemble parts. Install new valve disc and reassemble. Replace "O" ring if worn. Lubricate "O" ring (use grease suitable to fluid under control). If valve is controlling oxygen, use suitable lubricate. **Note: Do not grind in main valve.**

Steel Valves Fitted with Cage Type Trim

When dismantling steel valves fitted with cage trim, the seat insert, seat-insert cage and the seat-insert gasket may be easily removed for inspection, cleaning or rework after the bottom cap and other parts have been removed. When reassembling, always use new seat insert and bottom cap gaskets. Tighten bottom cap down evenly until the faces of the bottom cap and main body meet.

For steel valves without cage trim, use the procedures.

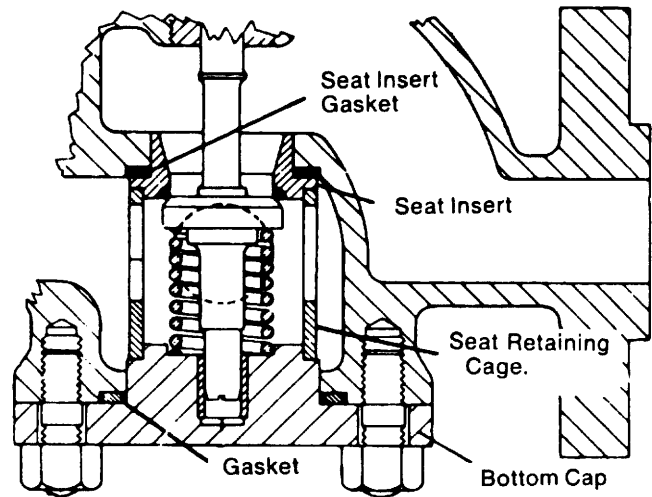

Figure 7 — Cage Type Trim

GPK-1T, GPK-2TC, GPK-2T AND GPK-4T PRESSURE REDUCING VALVES SIZES 1/2" THROUGH 4"

For TROUBLE FREE OPERATION and TIGHT SHUT-OFF
carefully follow the MAINTENANCE PROCEDURES outlined in this INSTRUCTION.

HOW TO IDENTIFY YOUR VALVE TYPE

GPK-1 T— Fitted with three (3) stainless steel diaphragms.

GPK-2T—This is a converted GPK-1T fitted with a SUPER-FLEX diaphragm and a metal spacer ring to control diaphragm crush.

GPK-4T— As" - 1As" sizes only with Super G body design and resilient seat.

NOTE: If you wish to take advantage of the long-life expectancy of the new SUPERFLEX diaphragm, your GPK-1T can be easily converted to either a GPK-2TC or GPK-2T during your valve maintenance period.

DISASSEMBLY

1. Remove bolts and nuts from diaphragm cover and lift off cover. Take out diaphragm(s) and diaphragm disc. Remove spacer ring if used.
2. Remove bottom cap and bottom cap gasket, main valve and spring.
3. To remove seat ring, place seat ring wrench over lugs of ring and strike end of wrench with a hammer several times while holding wrench in place to loosen seat ring for removal.
4. Clean diaphragm disc, diaphragm cover and main body diaphragm seating surface including the rounded portion below diaphragm face. Cleaning is important as a diaphragm life can be decreased if diaphragm is allowed to flex over any rough or scaled areas. A rotary wire brush is excellent for cleaning these surfaces. Check diaphragm cover air connection making sure it is not plugged.
5. Clean and polish seat ring threads and flat face, bottom cap gasket face and threads, main valve guide in main body and main valve guide bushing in bottom cap (Bottom cap bushings are removable in 1/2" through 2" sizes). To polish main valve and guides, place them in a lathe and spin rapidly. Use 320 Aluminum Oxide cloth as polishing agent.

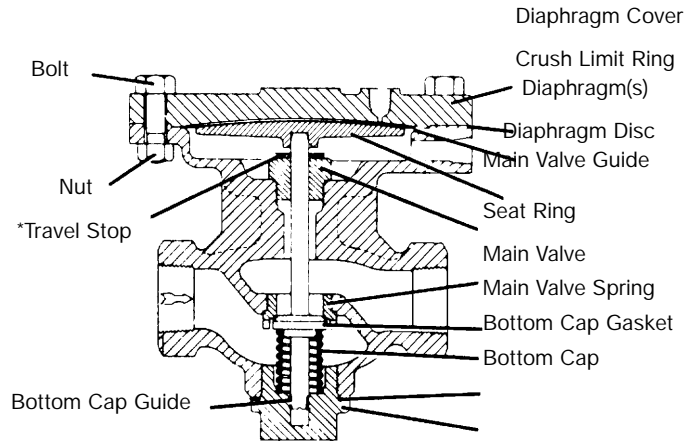

*1/2" through 2" GPK-2TC and GPK-2T do not have a travel stop.

6. After cleaning check all parts for erosion or damage. Replace if necessary.
7. Use a rotary wire brush and clean main body seat ring face and threads. Check for any erosion or damage to threads or flat face. All deposits must be removed from flat face as a metal to metal steam seal must be obtained between ring face and main body. Check bottom cap gasket face of main body. Gasket face must be flat and square; minor nicks should be removed with fine emery.
8. Blow out all loose scale etc. from body with air.

ASSEMBLY

1. Use a light coating of Never-Seez or similar lubricant on the first two threads only of seat ring. Blue in seat ring before final tightening making sure there is full, all-around contact between seat ring and main body flat faces. Tighten seat ring to 150 foot pounds torque. Install main valve guide and tighten.
2. FOR ALL-METAL SEATS ONLY: Place a small amount of extra fine lapping compound (Carborundum Grade CF) evenly spaced on main valve seating surface and lightly lap valve to seat ring. Remove all traces of compound from parts before reassembly.

3. Install main valve, main valve spring, bottom cap with guide bushing and bottom cap gasket. Tighten bottom cap.
4. Place travel stop washer over upper end of main valve stem followed by diaphragm disc (GPK-2T and GPK-2TC, sizes 1" through 2" do not have a travel stop).
5. Check height of disc. **IMPORTANT:** Height of diaphragm disc **MUST** be correct to obtain **TIGHT SHUT-OFF** of main valve. See Clearance Table and sketch for details. If **MINIMUM** clearance is **LESS** than that shown in Clearance Table, remove main valve and grind just enough metal from end of main valve stem to obtain proper clearance* (see view) If **MAXIMUM** clearance is **MORE** than that shown in Clearance Table, the rated travel of main valve will be reduced causing a reduction in the rated steam capacity of valve. If reduced capacity is great enough to affect system operation, a new seat ring and main valve should be installed.
6. GPK-1T Type—Replace the three diaphragms making sure the lower two leaves are those having a small bleed hole. The upper or top diaphragm is solid and does not have a bleed hole. GPK-2TC and GPK-2T Types — Replace SUPERFLEX DIAPHRAGM.
7. Loosen bottom cap sufficiently until diaphragm disc rests against main valve guide or travel stop if one is used. Place SUPERFLEX diaphragm on top of disc and center into recess of valve body. Replace diaphragm cover spacer ring on GPK-2TC only. In-stall diaphragm cover and tighten nuts evenly and securely. Retighten bottom cap.
8. If possible check valve for tight seating, using steam pressure equal to actual operating pressure before installing valve in line.
9. **BEFORE INSTALLING VALVE:** Clean strainer at in-let of valve and blow out piping including impulse pipe. Check traps for proper operation. Check pressure gages to make sure they read pressure correctly.

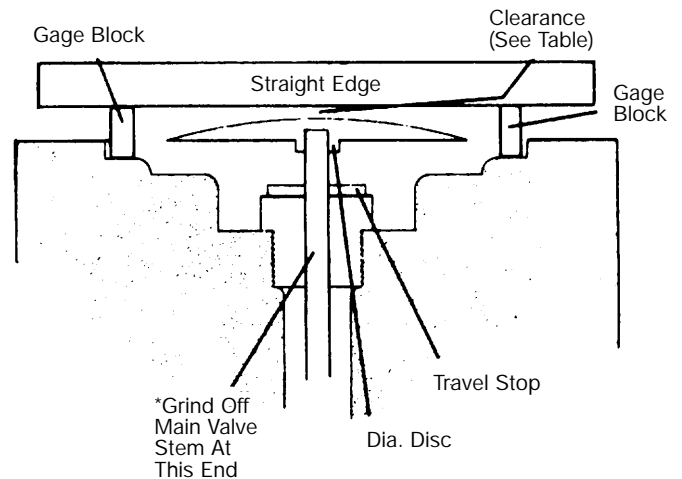

CLEARANCE TABLE

VALVE SIZE	GAGE BLOCK HEIGHT	MINIMUM CLEARANCE	MAXIMUM CLEARANCE
½" - 1½"	.187 + .000 - .022	.073 to .071	.100
1½" - 2"	.218 + .000 - .002	.076 to .074	.103
2½" - 4"	.312 + .000 - .002	.024 to .022	.066

To check disc height, place two gage blocks on flat of diaphragm face opposite each other. Place a straight edge across blocks and measure clearance between bottom edge of straight edge and top of diaphragm disc as shown in sketch.

CAST /DUCTILE IRON GP, TYPE DIRECT, DIAPHRAGM OPERATED REDUCING VALVES

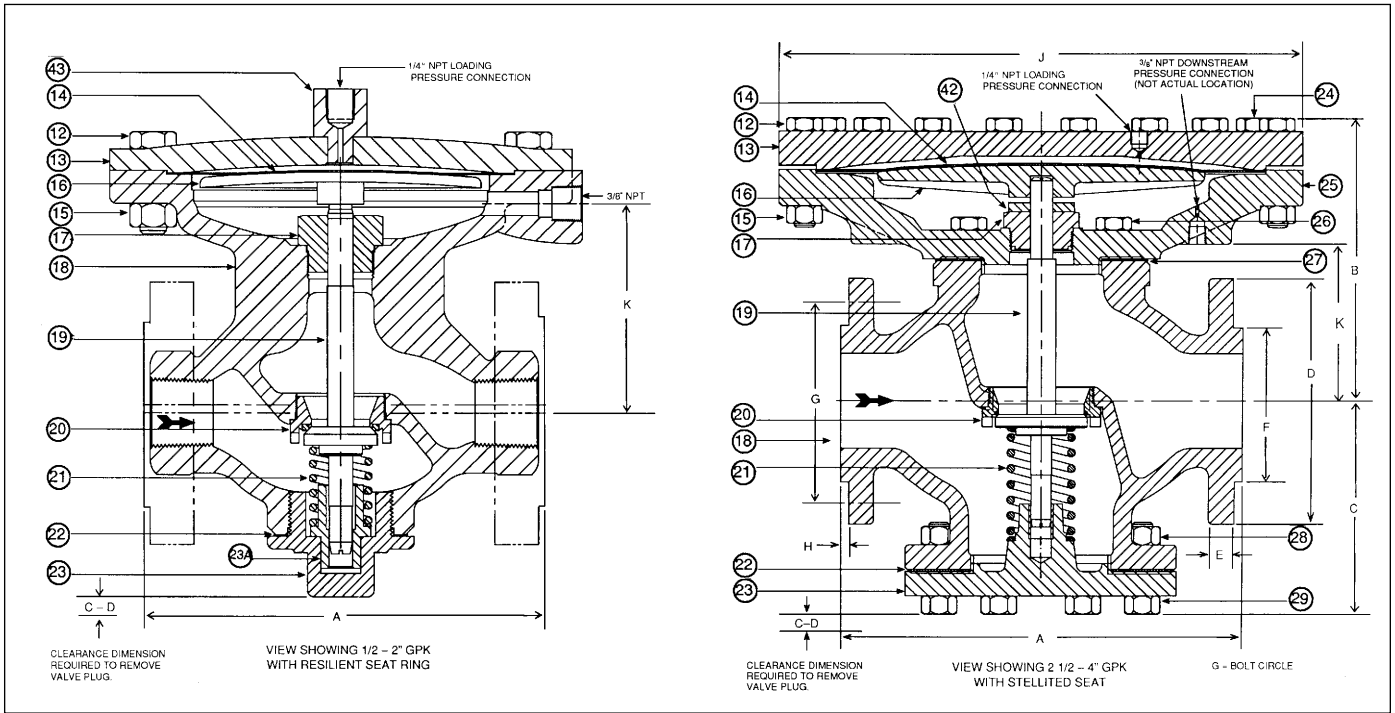

DIMENSIONS IN INCHES AND MILLIMETERS

NOMINAL PIPE SIZE	A	B	C	C-D	D	E	F	G	H	J	K	BOLT HOLE	NO. OF HOLES	BOLT SIZE	NET WT.
THREADED															
1/2"	6-1/8	5-1/2	3-3/8	6-3/8	—	—	—	—	—	8-5/8	3-5/8	—	—	—	33 lb.
15 mm	155.6	139.7	85.7	161.9	—	—	—	—	—	219.1	92.1	—	—	—	15 kg.
3/4"	6-1/2	5-1/16	3-5/16	6-3/8	—	—	—	—	—	8-5/8	3-5/8	—	—	—	36 lb.
20 mm	165.1	128.6	84.1	161.9	—	—	—	—	—	219.1	92.1	—	—	—	16.3 kg.
1"	7-1/4	5-1/4	3-3/8	6-3/8	—	—	—	—	—	8-5/8	4	—	—	—	42 lb.
25 mm	184.2	133.3	85.7	161.9	—	—	—	—	—	219.1	101.6	—	—	—	19.1 kg.
1-1/4"	7-5/8	5-9/16	3-15/16	6-7/8	—	—	—	—	—	10-1/4	4-1/8	—	—	—	55 lb.
32 mm	193.7	141.3	100.0	174.6	—	—	—	—	—	260.4	104.4	—	—	—	24.9 kg.
1-1/2"	8-1/2	5-3/4	4-1/2	7-7/8	—	—	—	—	—	10-1/4	4-5/16	—	—	—	56 lb.
40 mm	215.9	146.0	114.3	200.0	—	—	—	—	—	260.4	109.5	—	—	—	25.4 kg.
2"	8-1/2	5-3/4	4-1/2	7-7/8	—	—	—	—	—	10-1/4	4-5/16	—	—	—	56 lb.
50 mm	215.9	146.0	114.3	200.0	—	—	—	—	—	260.4	109.5	—	—	—	25.4 kg.
125# ANSI FLANGED															
2"	10	6-1/2	4-7/16	10	6	11/16	—	4-3/4	—	10-1/4	4-5/16	3/4	4	5/8	70 LB
50MM	254.0	165.1	112.1	254.0	152.4	17.5	—	121.6	—	260.4	109.5	19.1	4	15.9	31.8 KG
2-1/2"	10-7/8	7-3/16	5-1/2	7-1/8	7	11/16	—	5-1/2	—	16	4	3/4	4	5/8	192 LB
65MM	276.2	182.6	139.7	181.0	177.8	17.5	—	139.7	—	406.4	101.6	19.1	4	15.9	89.4 KG
3"	11-3/4	8-11/16	6-1/2	8	7-1/2	3/4	—	6	—	16	4-13/16	3/4	4	5/8	220 LB
80MM	298.5	220.6	165.1	203.2	190.5	19.1	—	152.4	—	406.4	122.2	19.1	4	15.9	99.7 KG
4"	13-7/8	9-15/16	7-5/16	9-1/4	9	15/16	—	7-1/2	—	16	6-1/8	3/4	8	5/8	247 KG
100MM	352.4	252.4	184.2	235.0	228.6	23.8	—	190.5	—	406.4	155.5	19.1	8	15.9	112.3 KG
250# ANSI FLANGED															
1-1/2"	10-1/2	5-13/16	4-7/16	7-7/8	6-1/8	13/16	3-9/16	4-1/2	1/16	10-1/4	4-3/8	7/8	4	3/4	74 LB
44MM	266.7	147.6	112.7	200.0	155.6	20.6	90.5	114.3	1.6	260.4	111.1	22.2	4	19.1	33.6 KG
2"	10-1/2	5-13/16	4-7/16	7-7/8	6-1/2	1	4-3/16	5	1/16	10-1/4	4-3/8	3/4	8	5/8	74 LB
50MM	266.7	147.6	112.7	200.0	165.1	25.4	160.3	127.0	1.6	260.4	111.1	19.1	8	15.9	22.6 LB
2-1/2"	11-1/2	7-3/8	5-1/2	7-1/8	7-1/2	1	4-15/16	5-7/8	1/16	16	4	7/8	8	3/4	197 LB
65MM	292.1	187.3	139.7	180.9	190.5	25.4	125.4	149.2	1.6	406.4	101.6	22.2	8	19.1	89. KG
3"	12-1/2	8-5/8	6-3/8	8	8-1/4	1-1/8	5-11/16	6-5/8	1/16	16	5-1/4	7/8	8	3/4	230 LB
80MM	317.5	219.0	161.9	203.2	209.6	28.6	144.5	168.3	1.6	406.4	133.3	22.2	8	19.1	104.3 KG
4"	14-1/2	9-15/16	7-5/16	9-1/4	10	1-1/4	6-15/16	7-7/8	1/16	16	6-5/16	7/8	8	3/4	280 LB
100MM	368.3	252.4	185.7	235.0	254.0	31.7	176.2	200.0	1.6	406.4	160.3	22.2	8	19.1	127.3 kg

30/4.4.1.1

PARTS LIST, GPK & VARIANTS:

WHEN ORDERING PARTS, GIVE SIZE, CLASS, PART NAME, AND PART REFERENCE NUMBER FROM TABLE BELOW. USE PART NUMBER ONLY TO LOCATE PART ON DRAWING.

PART NO.	PART NAME	MATERIAL	MATERIAL SPECIFICATION	QTY.
A) COMMON PARTS:				
12	BOLT	STEEL	COMMERCIAL	(1)
15	NUT	STEEL	COMMERCIAL	(1)
16	DIAPHRAGM DISC	(NOTE 2)	(NOTE 2)	1
17*	MAIN VALVE GUIDE	BRONZE	ASTM-B124, ALLOY 3	1
18	MAIN BODY, THREADED	CAST IRON	ASTM-A126, CL. B	1
18	MAIN BODY, 125# FLANGED	CAST IRON	ASTM-A126, CL. B	1
18	MAIN BODY, 250# FLANGED	CAST IRON	ASTM-A126, CL. B	1
18	MAIN BODY, THRD. -GPD	DUCTILE IRON	ASTM-A395, GR. 6-40-18	1
19	MAIN VALVE COMPLETE	SST, P.H.	ASTM-A564, GR. 630	1
21*	MAIN VALVE SPRING	SST	AISI TYPE 301	1
22+	BOTTOM CAP GASKET	COPPER	ASTM-B152	1
23	BOTTOM CAP (NOTE 3)	(NOTE 4)	NOTE 4	1
23A	BOTTOM CAP BUSHING	BRONZE	ASTM-B124, ALLOY 3	1
24	CAP SCREW	STEEL	ASTM-A193, GR. B7	(5)
25	DIAPHRAGM BASE	CAST IRON	ASTM-A126, CL. B	1
26	BOLT	STEEL	ASTM-A193, GR. B7	(6)
27+	DIAPHRAGM BASE GASKET	SHEET PACKING	COMMERCIAL	1
28	NUT	STEEL	ASTM-A194, GR. 2H	8
29	BOLT	STEEL	ASTM-A193, GR. B7	8
	SEAT RING WRENCH	STEEL	ASTM-A519, GR. 1015	1
B) 1/2" - 1-1/2" GPK-4, 2" - 4" GPK - 1, 1/2" & 3/4" GPD-4, 1/2" - 1-1/2" GPK-4S, 2" GPK-1S, 1/2" & 3/4" GPD-4S				
13	DIAPHRAGM COVER	CARBON STEEL	ASTM-A285, GR. C	1
14+	DIAPHRAGM	SST	AISI TYPE 316	2
20*	SEAT RING, -4/-1	(NOTE 7)	AISI TYPE 416	1
20*	SEAT RING, -4S/ -1S	STELLITED SST	AISI TYPE 416	1
43	ADAPTER	BRASS	ASTM-B16	1
C) 1/2" - 1-1/2" GPK-4T, 2" - 4" GPK-2T, 1/2" & 3/4" GPD-4T. 1/2" - 1-1/2" GPK-4TS, 2" GPK-2TS, 1/2" & 3/4" GPD-4TS:				
13	DIAPHRAGM COVER (NOTE 9)	CARBON STEEL	ASTM-A285, GR. C	1
14+	DIAPHRAGM	TEFLON	COMMERCIAL	1
20*	SEAT RING, -4T/ -2T	(NOTE 7)	AISI TYPE 416	1
20*	SEAT RING -4TS/ -2TS	STELLITED SST	AISI TYPE 416	1
42	TRAVEL STOP WASHER	BRASS	ASTM-B16	1

REFERENCE NUMBER — EACH SIZE

1/2"	3/4"	1"	1-1/4"	1-1/2"	2"	2-1/2"	3"	4"
65235	65235	65235	65235	65235	65235	58741	45812	45812
33816	33816	33816	33816	33816	33816	36147	36147	36147
33715	33715	33715	33663	33663	33663	36138	36138	36138
41294	41294	41294	41294	41294	41294	36145	36145	36145
41998	60357	60361	60365	60369	42060	—	—	—
—	—	—	—	—	41376	36332	36134	42878
—	—	—	—	60370	41377	36333	36135	42879
41998-28	60357-28	—	—	—	—	—	—	—
59281	59283	59279	59276	59265	59265	59267	59257	59274
48035	48035	48036	48036	48037	48037	48038	48038	48039
28138	28138	28139	28140	16511	16511	49654-67	49655-67	49656-67
55883-28	A33698	A33732	A33702	A33665	A33665	36310	36140	37061
56934	56934	56936	55880	56943	56943	—	—	—
—	—	—	9008	9008	9008	—	—	—
—	—	—	—	—	—	36309	36136	37060
—	—	—	—	—	—	4021	11886	11886
—	—	—	—	—	—	18524-67	18525-67	18526-67
—	—	—	—	—	—	3676	3677	3678
—	—	—	—	—	—	33754	45371	12984
28066	28066	28067	28068	28069	28069	53156	53157	53159
65395	65395	65395	65398	65398	65398	42869	42869	42869
46729	46729	46729	45953	45953	45953	58640	58640	58640
60401	60402	60403	60404	60405	60405	9448	9569	11970
9821	9445	9544	9446	9447	9447	—	—	—
65393	65393	65393	65393	65393	65393	(NOTE 8)	(NOTE 8)	(NOTE 8)
60028	60028	60028	60029	60029	60029	60030	60030	60030
60022	60022	60022	60023	60023	60023	60024	60024	60024
60401	60402	60403	60404	60405	60405	9448	9569	11970
9821	9445	9544	9446	9447	9447	—	—	—
—	—	—	—	—	—	59404	59404	59404

PART NO.	PART NAME	MATERIAL	MATERIAL SPECIFICATION	QTY.
A) 1/2" - 1-1/2" GPKC-4, 2" -4" GPKC:				
13	DIAPHRAGM COVER	CARBON STEEL	ASTM-A285, GR. C	1
14+	DIAPHRAGM SET (NOTE 10)	SST	AISI TYPE 316	1
20*	SEAT RING	(NOTE 7)	AISI TYPE 416	1
43	ADAPTER	BRASS	ASTM-B16	1
E) 1/2" - 1-1/2" GPK-4V, 2" - 4" GPK - 1V, 1/2" - 1-1/2" GPK-4VS, 2" GPK-1VS: (NOTE 11)				
13	DIAPHRAGM COVER	CARBON STEEL	ASTM-A285, GR. C	1
14+	DIAPHRAGM	SST	AISI TYPE 316	2
17	MAIN VALVE GUIDE	BRONZE	COMMERCIAL	1
20*	SEAT RING, - 4/ -1V	(NOTE 7)	AISI TYPE 416	1
20*	SEAT RING, - 4VS/ -1VS	STELLITED SST	AISI TYPE 416	1
35+	WIPER	TEFLON	COMMERCIAL	1
36*	BUSHING	BRONZE	COMMERCIAL	1
37	RETAINING RING	COPPER	COMMERCIAL	1
38	VACUUM BREAKER VALVE	ALUMINUM	COMMERCIAL	1
39	VAC. BREAKER VALVE DISC	VITON A	COMMERCIAL	1
43	ADAPTER	BRASS	ASTM-B16	1
F) 1/2" - 1-1/2" GPAK-4, 2" - 4" GPAK-2:				
13	DIAPHRAGM COVER	(NOTE 12)	(NOTE 12)	1
14+	DIAPHRAGM	RUBBER	COMMERCIAL	1
17	MAIN VALVE GUIDE	BRONZE	ASTM-B124, ALLOY 3	1
19*	MAIN VALVE COMPLETE	(NOTE 13)	(NOTE 13)	1
20*	SEAT RING	BRONZE	ASTM-A124, ALLOY 3	1
30	O-RING	SYNTH, RUBBER	COMMERCIAL	1
31*	MAIN VALVE STEM	CAST BRONZE	ASTM-A143, ALLOY 903	1
32+	MAIN VALVE DISC	SYNTH, RUBBER	COMMERCIAL	1
33*	DISC HOLDER	BRONZE	ASTM-B139	1
34*	MAIN VALVE NUT	SST	AISI TYPE 302	1
40+	MAIN VALVE DISC COMPLETE	RUBBER/BRONZE	COMMERCIAL	1
41*	RETAINING WASHER	BRONZE	ASTM-B124, ALLOY 3	1
	ORIFICE DISC	SST	AISI TYPE 416	1

REFERENCE NUMBER — EACH SIZE

1/2"	3/4"	1"	1-1/4"	1-1/2"	2"	2-1/2"	3"	4"
65395	65395	65395	65398	65398	65398	56626	56626	56626
55062	55062	55062	55063	55063	55063	55064	55064	55064
60401	60402	60403	60404	60405	60405	9448	9569	11970
65394	65394	65394	65394	65394	65394	(NOTE 8)	(NOTE 8)	(NOTE 8)
65395	65395	65395	65398	65398	65398	42869	42869	42869
46729	46729	46729	45953	45953	45953	58640	58640	58640
51455	51455	51455	51455	51455	51455	53378	53378	53378
60401	60402	60403	60404	60405	60405	9448	9569	11970
9821	9445	9544	9446	9447	—	—	—	—
38713	38713	38713	38713	38713	38713	53377	53377	53377
38715	38715	38715	38715	38715	38715	53376	53376	53376
38725	38725	38725	38725	38725	38725	53382	53382	53382
53951	53951	53951	53951	53951	53951	53951	53951	53951
53952	53952	53952	53952	53952	53952	53952	53952	53952
65393	65393	65393	65393	65993	65393	(NOTE 8)	(NOTE 8)	(NOTE 8)
51449	51449	51449	51453	51453	51453	49856	49856	49856
50655-95	50655-95	50655-95	50656-95	50656-95	50656-95	49855-95	49855-95	49855-95
60310	60310	60310	60310	60310	60310	47792	47792	47792
43335	43335	43350	43362	43369	43369	—	—	—
23403	23403	24696	24689	24676	24676	23415	24730	24786
23656-94	23656-94	23656-94	23656-94	23656-94	23656-94	47671-94	47671-94	47671-94
36187	36187	38202	37992	38557	38557	57114	57114	47208
23405	23405	24614	24615	43144	43144	—	—	—
23404	23404	23698	24691	43142	43142	—	—	—
24801	24801	24699	24693	38585	38585	24839	24839	24857
—	—	—	—	—	—	57889	57889	57891
—	—	—	—	—	—	58597	58598	58599
48832	48832	48832	49725	49725	49725	56631	56631	56631

- NOTE 1: QUANTITY IS 12 FOR 1/2" TO 1" & 2" SIZES, 14 FOR 1-1/4" & 1-1/2" SIZES, AND 20 FOR 2-1/2" TO 4" SIZES.
- NOTE 2: MATERIAL FOR 1/2" TO 2" SIZES IS CARBON STEEL/COMMERCIAL AND FOR 2-1/2" TO 4" SIZES IS CAST BRONZE/ASTM-B61.
- NOTE 3: 2-1/2" - 4" BOTTOM CAP IS FURNISHED COMPLETE WITH BOTTOM CAP BUSHING. PART NO.23A BUSHING IS FURNISHED SEPARATELY FOR 1/2" - 2" SIZES.
- NOTE 4: MATERIAL FOR 1/2" TO 2" SIZES IS DUCTILE IRON/STM-A395, GR. 60-4-18, AND FOR 2-1/2" TO 4" SIZES IS CAST IRON/ASTM-A126, CL. B.
- NOTE 5: QUANTITY IS 2 FOR 1-1/4" & 1-1/2" SIZES AND 4 FOR 2" SIZE.
- NOTE 6: QUANTITY IS 6 FOR 3" SIZE AND 8 FOR 2-1/2" & 4" SIZES.
- NOTE 7: MATERIAL IS SST/TEFLON FOR 1/2" TO 2" SIZES AND STELLITED SST FOR 2-1/2" TO 4" SIZES.
- NOTE 8: ADAPTER NOT REQUIRED.
- NOTE 9: INCLUDES EXTERNAL INTEGRAL ADAPTER FOR 1/2" TO 2" SIZES.
- NOTE 10: 2 LEAVES, BOTTOM DIAPHRAGM HAS BLEED HOLE.
- NOTE 11: VACUUM BREAKER VALVE, REFERENCE NUMBER A53951, MUST BE LISTED AS A SEPARATE LINE ITEM WHEN ORDERING NEW GPK - 4V/ - 1V/ - 4VS/ - 1VS UNITS.
- NOTE 12: MATERIAL FOR 1/2" TO 2" SIZES IS CAST IRON/ASTM-A126, CL. B, AND FOR 2-1/2" TO 4" SIZES IS CARBON STEEL/ASTM-A285, GR. C.
- NOTE 13: MAIN VALVE COMPLETE MAY BE FURNISHED AS INDIVIDUAL PARTS.
FOR 1/2" TO 2" SIZES, SEE PART NUMBERS 30, 31, 32, 33, & 34.
FOR 2-1/2" TO 4" SIZES, SEE PART NUMBERS 30, 31, 34, 40, & 41.

+ RECOMMENDED SPARE PARTS.

* THESE PARTS SHOULD BE ON HAND, PLUS RECOMMENDED SPARE PARTS, WHEN OVERHAULING THIS EQUIPMENT.

FOR CAST BRONZE GP TYPE DIRECT, DIAPHRAGM OPERATED REDUCING VALVES, SEE DRAWING 30/4.1.1.2.

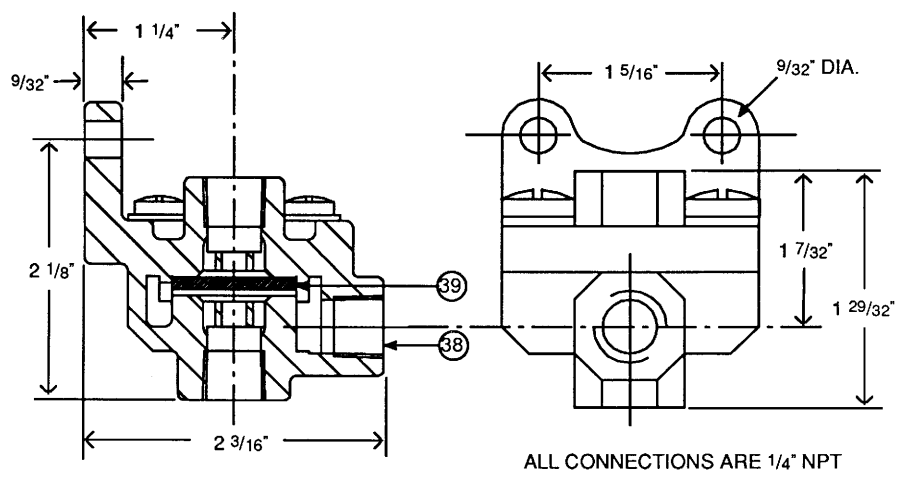
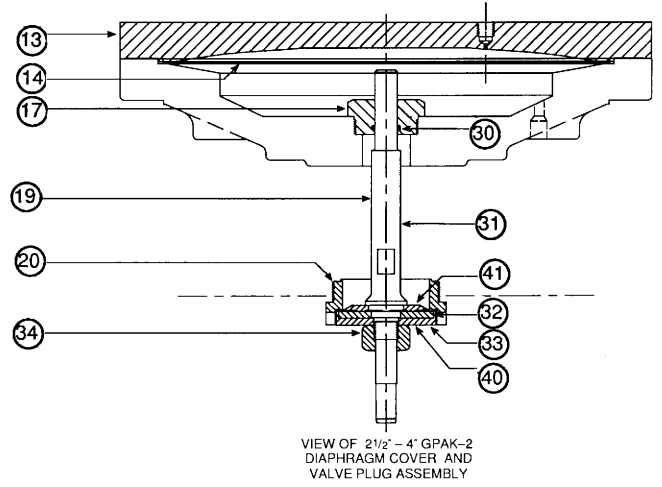
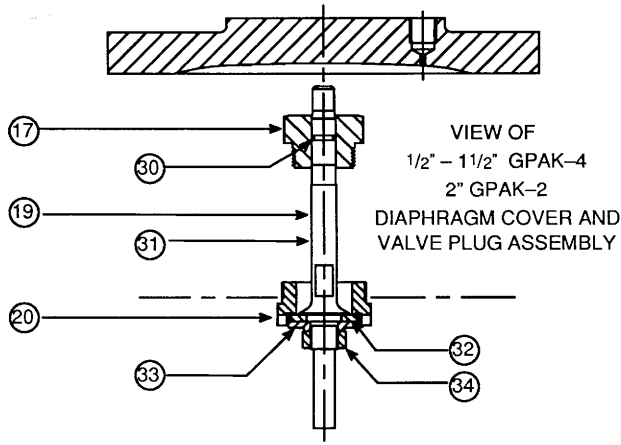

VIEW OF VACUUM BREAKER VALVE
FOR GPK-V UNITS

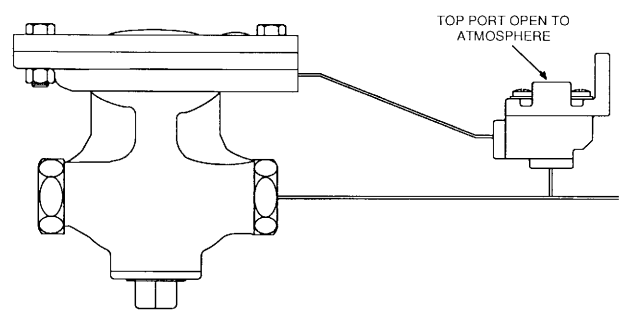
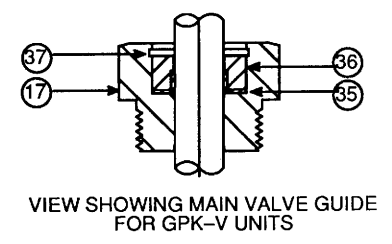

TYPICAL INSTALLATION

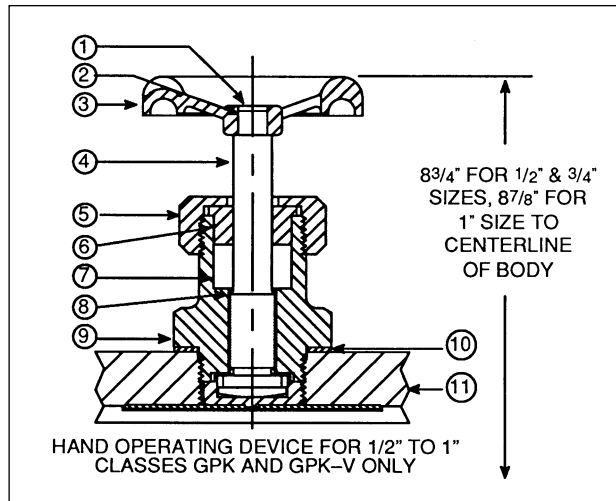

PART NO.	PART NAME	MATERIAL	MATERIAL SPECIFICATION	QTY.	REFERENCE NUMBERS 1/2" - 1"
1	SCREW	STEEL	COMMERCIAL	1	24726
2	WASHER	STEEL	COMMERCIAL	1	27649
3	HANDWHEEL	BRONZE	ASTM-B62	1	20616
4*	STEM COMPLETE	STAINLESS STEEL	AISI TYPE 302	1	35618
5	GLAND NUT	BRASS	ASTM-B16	1	20409
6	GLAND	BRASS	ASTM-B16	1	33684
7+	PACKING RING	MOLDED	COMMERCIAL	3	54769
8	RETAINING WASHER	BRASS	ASTM-B16	1	33756
9	BONNET	PHOSPHOR BRONZE	ASTM-B139	1	33685
10	BONNET WASHER	ARMSTRONG	COMMERCIAL	1	33755
11	DIAPHRAGM COVER	CAST IRON	ASTM-A126, CL. B	1	33719

CAST BRONZE GP TYPE DIRECT, DIAPHRAGM OPERATED REDUCING VALVES

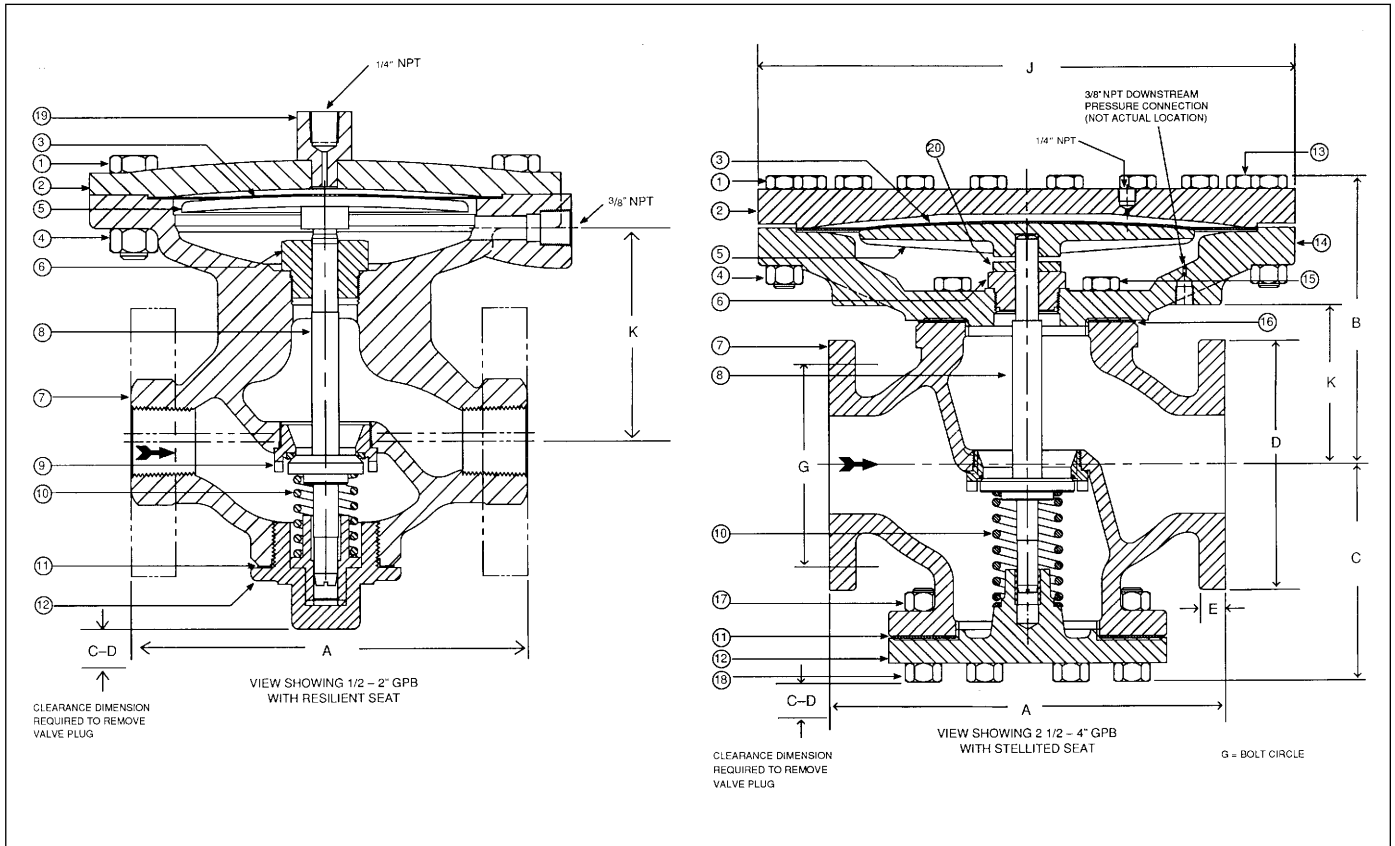

DIMENSIONS IN INCHES AND MILLIMETERS													
NOMINAL PIPE SIZE	A	B	C	C-D	D	E	G	J	K	BOLT HOLE	NO. OF HOLES	BOLT SIZE	NET WT.
THREADED													
1/2"	6-1/8	5-1/2	3-3/8	6-3/8	—	—	—	8-5/8	3-5/8	—	—	—	33 lb.
15 mm	155.6	139.7	85.7	161.9	—	—	—	219.1	92.1	—	—	—	15 kg.
3/4"	6-1/2	5-1/16	3-5/16	6-3/8	—	—	—	8-5/8	3-5/8	—	—	—	36 lb.
20 mm	165.1	128.6	84.1	161.9	—	—	—	219.1	92.1	—	—	—	16.3 kg.
1"	7-1/4	5-1/4	3-3/8	6-3/8	—	—	—	8-5/8	4	—	—	—	42 lb.
25 mm	184.2	133.3	85.7	161.9	—	—	—	219.1	101.6	—	—	—	19.1 kg.
1-1/4"	7-5/8	5-9/16	3-15/16	6-7/8	—	—	—	10-1/4	4-1/8	—	—	—	55 lb.
32 mm	193.7	141.3	100.0	174.6	—	—	—	260.4	104.4	—	—	—	24.9 kg.
1-1/2"	8-1/2	5-3/4	4-1/2	7-7/8	—	—	—	10-1/4	4-5/16	—	—	—	56 lb.
40 mm	215.9	146.0	114.3	200.0	—	—	—	260.4	109.5	—	—	—	25.4 kg.
2"	8-1/2	5-3/4	4-1/2	7-7/8	—	—	—	10-1/4	4-5/16	—	—	—	56 lb.
50 mm	215.9	146.0	114.3	200.0	—	—	—	260.4	109.5	—	—	—	25.4 kg.
300# ANSI FLANGED													
1/2"	7-1/2	5-1/8	3-1/4	8-11/16	3-3/4	9/16	2-5/8	8-5/8	3-5/8	5/8	4	1/2	—
15 mm	190.5	130.1	82.5	220.6	95.3	14.3	66.7	219.1	92.1	15.9	4	12.7	—
3/4"	7-3/4	5-1/8	3-1/4	8-11/16	4-5/8	5/8	3-1/4	8-5/8	3-5/8	3/4	4	5/8	—
20 mm	196.9	130.1	82.5	220.6	117.5	15.9	82.6	219.1	92.1	19.1	4	15.9	—
1"	8-1/4	5-7/16	3-5/16	9	4-7/8	5/8	3-1/2	8-5/8	3-29/32	3/4	4	5/8	—
25 mm	209.5	138.1	84.1	228.6	123.8	15.9	88.9	219.1	99.2	19.1	4	15.9	—
1-1/4"	9-1/4	5-3/4	3-15/16	10	5-1/4	21/32	3-7/8	10-1/4	4-1/8	3/4	4	5/8	—
32 mm	234.9	146.0	100.0	254.0	133.3	16.6	98.4	260.4	104.4	19.1	4	15.9	—
1-1/2"	10-1/2	5-13/16	4-1/2	7-7/8	6-1/2	11/16	4-1/2	10-1/4	4-5/16	7/8	4	3/4	74 lb.
40 mm	266.7	147.6	114.3	200.0	165.1	17.4	114.3	260.4	109.5	22.2	4	19.1	33.6 kg.
2"	10-1/2	5-13/16	4-1/2	7-7/8	6-1/2	13/16	5	10-1/4	4-5/16	3/4	8	5/8	74 lb.
50 mm	266.7	147.6	114.3	200.0	165.1	20.6	127.0	260.4	109.5	19.1	8	15.9	33.6 kg.
2-1/2"	11-1/2	7-13/16	5-1/2	7-1/8	7-1/2	7/8	5-7/8	16	4-1/8	7/8	8	3/4	197 lb.
65 mm	292.1	198.4	139.7	180.9	190.5	22.2	149.2	406.4	104.7	22.2	8	19.1	89.3 kg.
3"	12-1/2	8-5/8	6-3/8	8	8-1/4	1	6-5/8	16	4-7/8	7/8	8	3/4	230 lb.
80 mm	317.5	219.1	161.9	203.2	209.6	25.4	168.2	406.4	123.8	22.2	8	19.1	104.5 kg.
4"	14-1/2	9-15/16	7-5/16	9-1/4	10	1-1/16	7-7/8	16	6-3/16	7/8	8	3/4	280 lb.
100 mm	368.3	252.4	185.7	235.0	254.0	27.0	200.0	406.4	157.1	22.2	8	19.1	127.3 kg.

PARTS LIST, GPB & VARIANTS:

WHEN ORDERING PARTS, GIVE SIZE, CLASS, PART NAME, AND PART REFERENCE NUMBER FROM TABLE BELOW. USE PART NUMBER ONLY TO LOCATE PART ON DRAWING.

PART NO.	PART NAME	MATERIAL	MATERIAL SPECIFICATION	QTY.
A) COMMON PARTS:				
1	BOLT	STEEL	COMMERCIAL	(1)
4	NUT	STEEL	COMMERCIAL	(1)
5	DIAPHRAGM DISC	(NOTE 2)	(NOTE 2)	1
6*	MAIN VALVE GUIDE	BRONZE	ASTM-B124, ALLOY 3	1
7	MAIN BODY, THREADED	CAST BRONZE	ASTM-B61	1
7	MAIN BODY, 300# FLANGED	CAST BRONZE	ASTM-B61	1
8	MAIN VALVE COMPLETE	SST, P.H.	ASTM-A564, GR. 630	1
10*	MAIN VALVE SPRING	SST	AISI TYPE 301	1
11+	BOTTOM CAP GASKET	COPPER	ASTM-B152	1
12	BOTTOM CAP	CAST BRONZE	ASTM-B61	1
13	CAP SCREW	STEEL	ASTM-A193, GR. B7	(3)
14	DIAPHRAGM BASE	CAST BRONZE	ASTM-B61	1
15	BOLT	STEEL	ASTM-A193, GR. B7	(4)
16+	DIAPHRAGM BASE GASKET	SHEET PACKING	COMMERCIAL	1
17	NUT	STEEL	ASTM-A194, GR. 2H	8
18	BOLT	STEEL	ASTM-A193, GR. B7	8
	SEAT RING WRENCH	STEEL	ASTM-A519, GR. 1015	1
B) 1/2" - 1-1/2" GPB-4, 2" - 4" GPB:				
2	DIAPHRAGM COVER	CARBON STEEL	ASTM-A285, GR. C	1
3+	DIAPHRAGM	SST	AISI TYPE 316	2
9*	SEAT RING	STELLITED SST	AISI TYPE 416	1
19*	ADAPTER	BRASS	ASTM-B16	1
C) 1/2" - 1-1/2" GPB-4T, 2" - 4" GPB-2T, 1/2" - 1-1/2" GPB-4TS, 2" GPB-2TS:				
2	DIAPHRAGM COVER (NOTE 8)	CARBON STEEL	ASTM-A285, GR. C	1
3+	DIAPHRAGM	TEFLON	COMMERCIAL	1
9*	SEAT RING, -4T/ -2T	(NOTE 6)	AISI TYPE 416	1
9*	SEAT RING -4TS/ -2TS	STELLITED SST	AISI TYPE 416	1
20	TRAVEL STOP WASHER	BRASS	ASTM-B16	1
D) 1/2" - 1-1/2" GPBC-4, 2" - 4" GPBC:				
2	DIAPHRAGM COVER	CARBON STEEL	ASTM-A285, GR. C	1
3+	DIAPHRAGM SET (NOTE 7)	SST	AISI TYPE 316	1
9*	SEAT RING	STELLITED SST	AISI TYPE 416	1
19	ADAPTER	BRASS	ASTM-B16	1

NOTE 1 : QUANTITY IS 12 FOR 1/2" TO 1" SIZES, 14 FOR 1-1/4" & 1-1/2" SIZES, AND 16 FOR 2-1/2" TO 4" SIZES.

NOTE 2: MATERIAL FOR 1/2" TO 2" SIZES IS CARBON STEEL/COMMERCIAL AND FOR 2-1/2" TO 4" SIZES IS CAST BRONZE/ASTM-B61.

NOTE 3: QUANTITY IS 2 FOR 1-1/4" & 1-1/2" SIZES AND 4 FOR 2" TO 4" SIZES.

NOTE 4: QUANTITY IS 6 FOR 3" SIZE AND 8 FOR 2-1/2" & 4" SIZES.

NOTE 5: ADAPTER NOT REQUIRED.

REFERENCE NUMBER — EACH SIZE

1/2"	3/4"	1"	1-1/4"	1-1/2"	2"	2-1/2"	3"	4"
65236	65236	65236	65235	65235	65235	58741	45812	45812
33816	33816	33816	33816	33816	33816	36147	36147	36147
33715	33715	33715	33663	33663	33663	42870	42870	42870
41294	41294	41294	41294	41294	41294	36145	36145	36145
41997	60356	60360	60364	60368	42031	—	—	—
41301	60359	60363	60367	60372	41379	42875	42877	42881
59281	59283	59279	59276	59265	59265	59267	59257	59274
48035	48035	48036	48036	48037	48037	48038	48038	48039
28138	28138	28139	28140	16511	16511	49654-67	49655-67	49656-67
41397	41397	41459	41460	41461	41461	42866	42867	42868
—	—	—	9008	9008	9008	45813	45813	45813
—	—	—	—	—	—	42871	42872	42873
—	—	—	—	—	—	4021	11886	11886
—	—	—	—	—	—	18524-67	18525-67	18526-67
—	—	—	—	—	—	3676	3677	3678
—	—	—	—	—	—	4488	36150	12984
28066	28066	28067	28068	28069	28069	53156	53157	53159
65395	65395	65395	65398	65398	65398	42869	42869	42869
46729	46729	46729	45953	45953	45953	58640	58640	58640
9821	9445	9544	9446	9447	9447	9448	9569	11970
65393	65393	65393	65393	65393	65393	(NOTE 5)	(NOTE 5)	(NOTE 5)
60028	60028	60028	60029	60029	60029	60030	60030	60030
60022	60022	60022	60023	60023	60023	60024	60024	60024
60401	60402	60403	60404	60405	60405	9448	9569	11970
9821	9445	9544	9446	9447	9447	—	—	—
—	—	—	—	—	—	59404	59404	59404
65395	65395	65395	65398	65398	65398	56626	56626	56626
55062	55062	55062	55063	55063	55063	55064	55064	55064
9821	9445	9544	9446	9447	9447	9448	9569	11970
65394	65394	65394	65394	65394	65394	(NOTE 5)	(NOTE 5)	(NOTE 5)

NOTE 6 : MATERIAL IS SST/TEFLON FOR 1/2" TO 2" SIZES AND STELLITED SST FOR 2-1/2" TO 4" SIZES.

NOTE 7: 2 LEAVES, BOTTOM DIAPHRAGM HAS BLEED HOLE.

NOTE 8: INCLUDES EXTERNAL INTEGRAL ADAPTER FOR 1/2" SIZES.

+ RECOMMENDED SPARE PARTS.

* THESE PARTS SHOULD BE ON HAND, PLUS RECOMMENDED SPARE PARTS, WHEN OVERHAULING THIS EQUIPMENT.

**DIRECT DIAPHRAGM OPERATED
PRESSURE REDUCING VALVES**

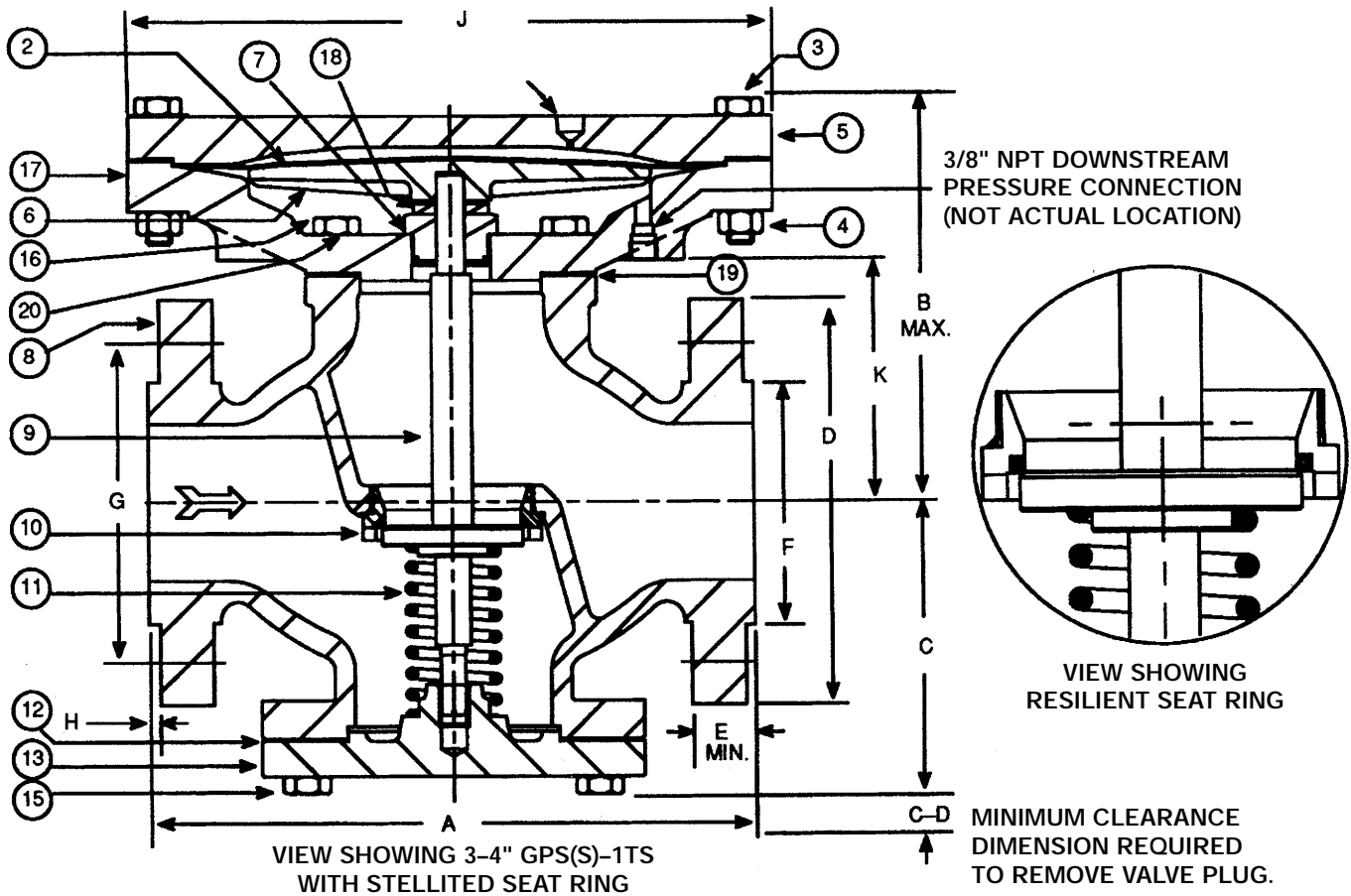
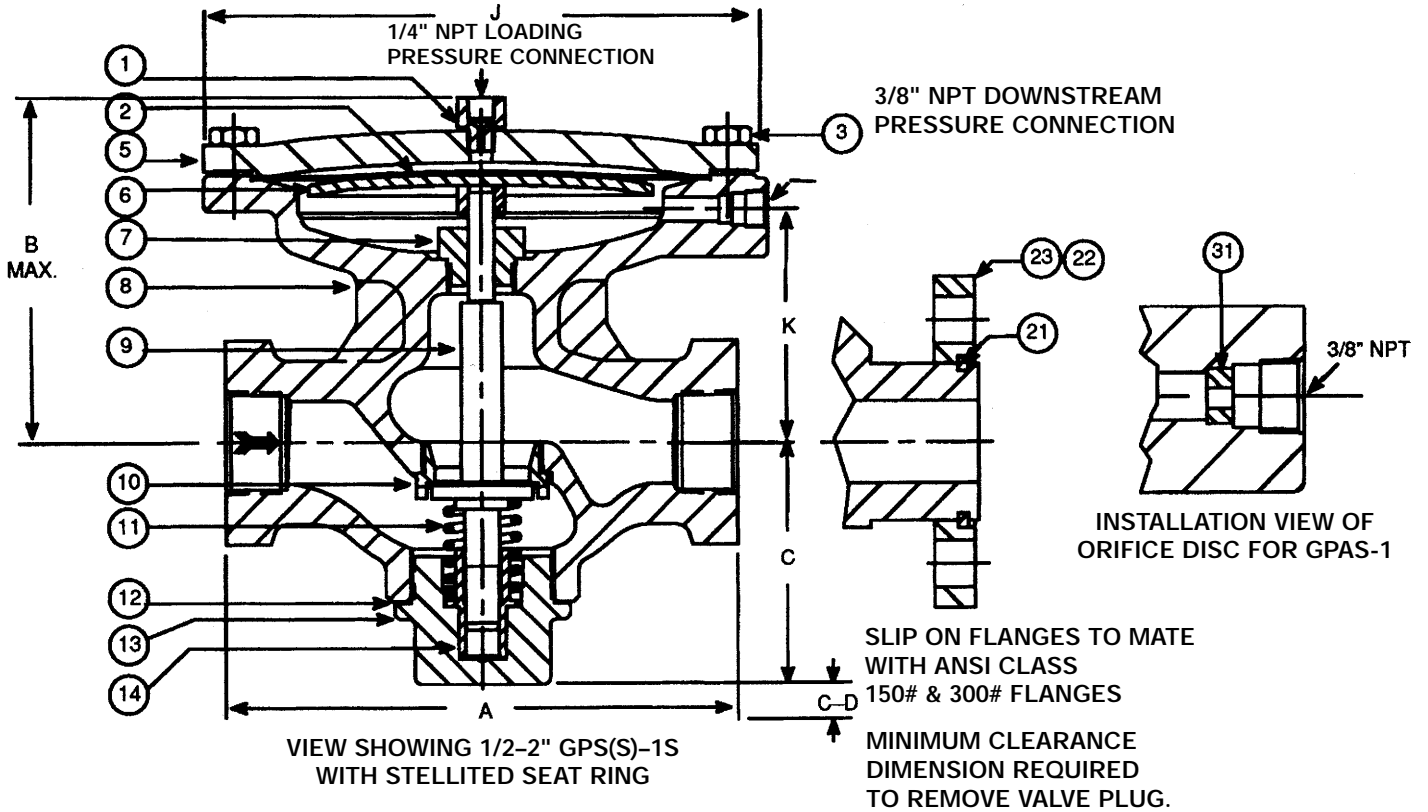

DIMENSIONS IN INCHES AND MILLIMETERS															
NOMINAL PIPE SIZE	A	B	C	C-D	D	E	F	G	H	J	K	BOLT HOLE	NO. OF HOLES	BOLT SIZE	NET WT.
THREADED															
1/2" 15 mm	8-1/2 215.9	5-1/2 139.7	3-3/8 85.7	6-3/8 161.9	—	—	—	—	—	8-5/8 219.1	3-5/8 92.1	—	—	—	39 lb. 17.7 kg
3/4" 20 mm	8-1/2 215.9	5-1/2 128.6	3-3/8 84.1	6-3/8 161.9	—	—	—	—	—	8-5/8 219.1	3-5/8 92.1	—	—	—	41.8 lb. 19.0 kg
1" 25 mm	8-1/2 215.9	5-1/4 139.7	3-1/2 88.9	6-3/8 161.9	—	—	—	—	—	8-5/8 219.1	3-29/32 99.2	—	—	—	48.7 lb. 22.2 kg
1-1/2" 40 mm	9-1/2 241.3	6-1/16 154.0	4-1/2 114.3	7-1/2 190.5	—	—	—	—	—	10-1/4 260.4	4-5/16 109.5	—	—	—	65 lb. 29.5 kg
2" 50 mm	11-1/2 292.1	6-1/16 154.0	4-1/2 114.3	7-1/2 190.5	—	—	—	—	—	10-1/4 260.4	4-5/16 109.5	—	—	—	70 lb. 31.8 kg
150# ANSI FLANGED															
1" 25MM	8-1/2 215.9	5-1/2 139.7	3-1/2 88.9	6-3/8 161.9	4-1/4 108.0	9/16 14.3	2 50.8	3+1/8 79.4	1/16 1.6	8-5/8 219.1	3-29/32 99.2	5/8 15.9	4	1/2 12.7	53 lb 24.1 kg
1-1/2" 40MM	9-1/2 241.3	6-1/16 154.0	4-1/2 114.3	7-1/2 190.5	5 127.0	11/16 17.5	2-7/8 73.0	3-7/8 98.4	1/16 1.6	10-1/4 260.4	4-5/16 190.5	5/8 15.9	4	1/2 12.7	68 lb 30.9 kg
2" 60MM	11-1/2 292.1	6-1/16 154.0	4-1/2 114.3	7-1/2 190.5	6 152.4	3/4 19.1	3-5/8 92.1	4-3/4 120.7	1/16 1.6	10-1/4 260.4	4-5/16 109.5	3/4 19.1	4	5/8 15.9	76 lb 34.5 kg
3" 80MM	11-3/4 298.5	8-7/8 225.4	6-5/8 168.3	9-1/2 241.3	7-1/2 190.5	15/16 23.8	5 127.0	6 152.4	1/16 1.6	16 406.4	4-7/8 123.8	3/4 19.1	4	5/8 15.9	256 lb 116 kg
4" 100MM	13-7/8 352.4	10-1/8 257.2	7-5/8 193.7	11-3/4 298.5	9 228.6	15/16 23.8	6-3/16 157.2	7-1/2 190.5	1/16 1.6	16 406.4	6-3/16 157.2	3/4 19.1	8	5/8 15.9	286.5 lb 130.2 kg
300# ANSI FLANGED															
1" 25MM	8-1/2 215.9	5-1/2 139.7	3-1/2 88.9	6-3/8 161.9	4-7/8 123.8	11/16 17.5	2 50.8	3-1/2 88.9	1/16 1.6	8-5/8 219.1	3-29/32 99.2	3/4 19.1	4	5/8 15.9	57 lb 25.9 kg
1-1/2" 40MM	9-1/2 241.3	6-1/16 154.0	4-1/2 114.3	7-1/2 190.5	6-1/8 155.6	13/16 20.6	2-7/8 73.0	4-1/2 114.3	1/16 1.6	10-1/4 260.4	4-5/16 109.5	7/8 22.2	4	3/4 19.1	72 lb 32.7 kg
2" 50MM	11-1/2 292.1	6-1/16 154.0	4-1/2 114.3	7-1/2 190.5	6-1/2 165.1	7/8 22.2	3-5/8 92.1	5 127.0	1/16 1.6	10-1/4 260.4	4-5/16 109.5	3/4 19.1	4	5/8 15.9	86 lb 39 kg
3" 80MM	12-1/2 317.5	8-7/8 225.4	6-5/8 168.3	9-1/2 241.3	8-1/4 209.6	1-1/8 28.6	5 127.0	6-5/8 168.3	1/16 1.6	16 406.4	4-7/8 123.8	7/8 22.2	8	3/4 19.1	267 lb 121.3 kg
4" 100MM	14-1/2 368.3	10-1/8 257.2	7-5/8 193.7	11-3/4 298.5	10 254.0	1-1/4 31.8	6-3/16 157.2	7-7/8 200.0	1/16 1.6	16 406.4	6-3/16 157.2	7/8 22.2	8	3/4 19.1	324.8 lb 147.6 kg

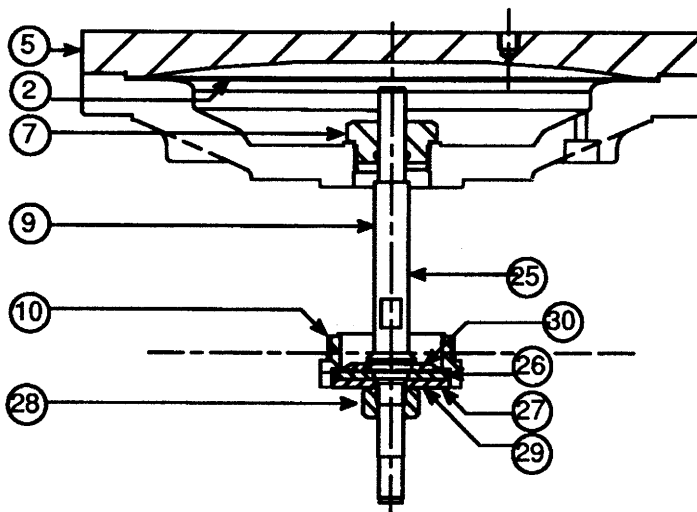

VIEW OF 3"-4" GPAS-1 DIAPHRAGM COVER
AND VALVE PLUG ASSEMBLY

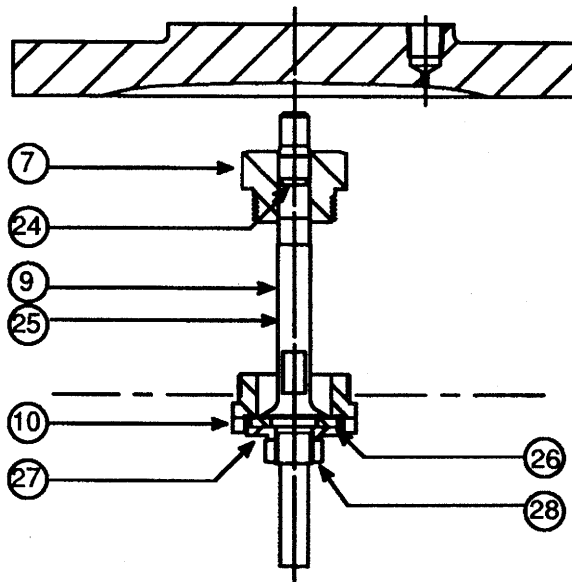

VIEW OF 1/2"-2" GPAS-1 DIAPHRAGM COVER
AND VALVE PLUG ASSEMBLY

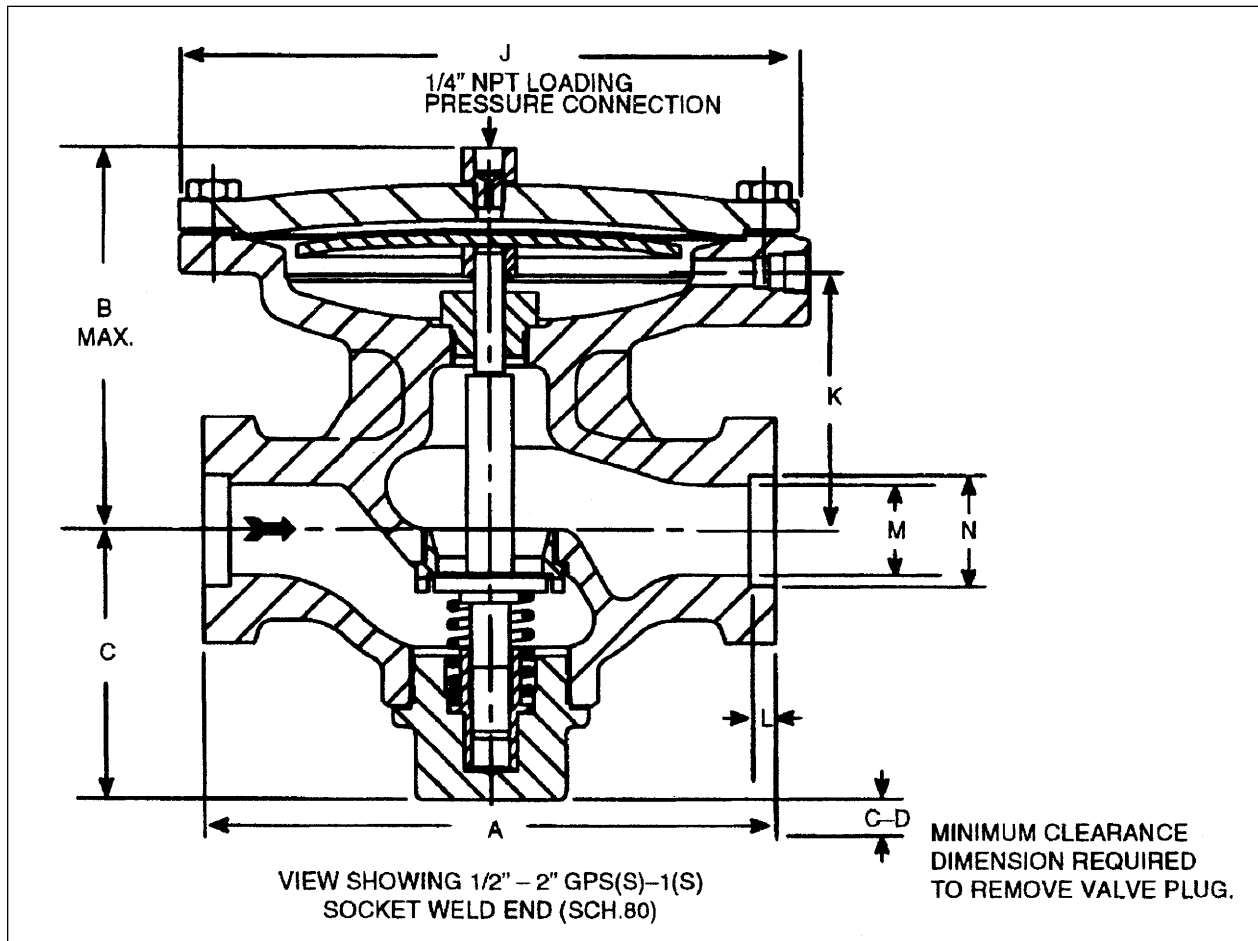

NOM. PIPE SIZE	A	B	C	C-D	J	K	L	M	N	NET WT.*
1/2" 15MM	8-1/2 215.9	5-1/2 139.7	3-3/8 85.7	6-3/8 161.9	8-5/8 219.1	3-5/8 92.1	3/8 9.5	35/64 13.9	.855 21.7	39 lb 17.7 kg
3/4" 20MM	8-1/2 215.9	5-1/2 139.7	3-3/8 85.7	6-3/8 161.9	8-5/8 219.1	3-5/8 92.1	1/2 12.7	3/4 19.1	1.065 27.1	41.8 lb 19.0 kg
1" 25MM	8-1/2 215.9	5-1/2 139.7	3-3/8 85.7	6-3/8 161.9	8-5/8 219.1	3-29/32 99.2	1/2 12.7	61/64 24.2	1.330 33.8	48.7 lb 22.2 kg
1-1/2" 40MM	9-1/2 241.3	6-1/16 154.0	4-1/2 114.3	7-1/2 190.5	10-1/4 260.4	4-5/16 109.5	1/2 12.7	1-1/2 38.1	1.915 48.6	65 lb 29.5 kg
2" 50MM	11-1/2 292.1	6-1/16 154.0	4-1/2 114.3	7-1/2 190.5	10-1/4 260.4	4-5/16 109.5	5/8 15.9	1-15/16 49.2	2.406 61.1	70 lb 31.8 kg

PARTS LIST, GPS-1 & VARIANTS:

WHEN ORDERING PARTS, GIVE SIZE, CLASS, PART NAME, AND PART REFERENCE NUMBER FROM TABLE BELOW. USE PART NUMBER ONLY TO LOCATE PART ON DRAWING.

PART NO.	PART NAME	MATERIAL	MATERIAL SPECIFICATION	QTY.
A) COMMON PARTS:				
1	ADAPTER	BRASS	ASTM-B16	1
3	BOLT	STEEL	COMMERCIAL	(NOTE 1)
4	NUT	STEEL	COMMERCIAL	(NOTE 17)
6	DIAPHRAGM DISC	(NOTE 9)	COMMERCIAL	1
7*	MAIN VALVE GUIDE	BRONZE	ASTM-B21, ALLOY C46400	1
8	BODY THREADED	CAST STEEL	ASTM-A216, GR, WCB	1
8	BODY S.O. FLG	CAST STEEL	ASTM-A216, GR, WCB	1
8	BODY 150# FLG	CAST STEEL	ASTM-A216, GR. WCB	1
8	BODY 300# FLG	CAST STEEL	ASTM-A216, GR. WCB	1
8	BODY S.W.E.	CAST STEEL	ASTM-A216, GR. WCB	1
9	MAIN VALVE COMPLETE	STAINLESS STEEL	AISI 17-4 PH	1
11	MAIN VALVE SPRING	STAINLESS STEEL	AISI TYPE 300	1
12+	BOTTOM CAP GASKET	COPPER	ASTM-B152	1
12+	BOTTOM CAP GASKET	NON-ASBESTOS	COMMERCIAL	1
13	BOTTOM CAP (NOTE 2)	CAST STEEL	ASTM-A216, GR. WCB	1
14	BOTTOM CAP BUSHING	BRONZE	ASTM-B21, ALLOY C46400	1
15	BOLT	STEEL	COMMERCIAL	8
16+	BOLT	STEEL	COMMERCIAL	(NOTE 5)
17	DIAPHRAGM BASE	CAST STEEL	ASTM-A216, GR. WCB	1
19	DIAPHRAGM BASE GASKET	SHEET PACKING	COMMERCIAL	1
20	LOCK WASHER	STEEL	COMMERCIAL	(NOTE 5)
21	RETAINING RING	STEEL	AISI 1018	2
22	SLIP-ON FLANGE, 150#	STEEL	COMMERCIAL	2
23	SLIP-ON FLANGE, 300#	STEEL	COMMERCIAL	2
	SEAT RING WRENCH	STEEL	ASTM-A519, GR. 1015	1
B) 1/2" - 4" GPS-1 & 1/2" - 4" GPS-1S				
2+	DIAPHRAGM	STAINLESS STEEL	AISI TYPE 316	2
5	DIAPHRAGM	CARBON STEEL	ASTM A-285, GR. C	1
10*	SEAT RING, -1	(NOTE 6)	(NOTE 6)	1
10*	SEAT RING, -IS	STELLITED SST	(NOTE 8)	1

+ RECOMMENDED SPARE PARTS.

* THESE PARTS, PLUS RECOMMENDED SPARE PARTS, SHOULD BE ON HAND WHEN OVERHAULING THIS EQUIPMENT.

REFERENCE NUMBER — EACH SIZE

1/2"	3/4"	1"	1-1/2"	2"	3"	4"
65393	65393	65393	65393	65393	(NOTE 3)	(NOTE 3)
30817	30817	30817	65236	65236	58741	58741
—	—	—	—	—	36147	36147
33715	33715	33715	33663	33663	36138	36138
41294	41294	41294	41294	41294	36145	36145
71284-03	71276-03	71287-03	71290+03	71499-03	—	—
—	—	71286-03	71292-03	71294-03	—	—
—	—	—	—	—	71501-03	71503-0-
—	—	—	—	—	71502-03	71504-03
72265-03	72267-03	72269-03	72271-03	72273-03	—	—
59281	59283	59279	59265	59265	59257	59274
48035	48035	48036	48037	48037	48038	48039
28138	28138	28139	16511	16511	—	—
—	—	—	—	—	49655-67	49656-67
71349-03	71649-03	71350-03	71351-03	71351-03	71342-03	71344-03
56934	56934	56936	56943	56943	—	—
—	—	—	—	—	71490	71491
—	—	—	—	—	45813	45813
—	—	—	—	—	71509-03	71510-03
—	—	—	—	—	18525-67	18526-67
—	—	—	—	—	66503	66503
—	—	71471	71472	71473	—	—
—	—	71474	71476	71478	—	—
—	—	71475	71477	71479	—	—
28066	28066	28067	28069	28069	53157	53159
46729	46729	46729	45953	45953	58640	58640
65395	65395	65395	65398	65398	42869	42869
60401	60402	60403	60405	60405	9569	11970
9821	9445	9544	9447	9447	—	—

PARTS LIST, GPS-1 & VARIANTS:

WHEN ORDERING PARTS, GIVE SIZE, CLASS, PART NAME, AND PART REFERENCE NUMBER FROM TABLE BELOW. USE PART NUMBER ONLY TO LOCATE PART ON DRAWING.

PART NO.	PART NAME	MATERIAL	MATERIAL SPECIFICATION	QTY.
C) 1/2" - 4" GPS-1T & 1/2" - 2" GPS-1TS (TEFLON DIAPHRAGM):				
2 +	DIAPHRAGM	TEFLON	COMMERCIAL	1
5	DIAPH. COVER (NOTES 3&4)	CARBON STEEL	ASTM-A285, GR. C	1
10 *	SEAT RING, -1T	(NOTE 6)	(NOTE 6)	1
10	SEAT RING, -1TS	STELLITED SST	(NOTE 8)	1
18	TRAVEL STOP WASHER	BRASS	ASTM-B16	1
D) 1/2" - 4" GPAS-1 (FOR AIR & GAS SERVICE)				
2 +	DIAPHRAGM	RUBBER	COMMERCIAL	1
5	DIAPH. COVER (NOTE 16)	CARBON STEEL	ASTM-A285, GR. C	1
7	MAIN VALVE GUIDE	BRONZE	ASTM-B21, ALLOY C46400	1
9	MAIN VALVE COMPLETE	(NOTE 11)	(NOTE 11)	1
10*	SEAT RING	BRONZE	ASTM-B21, ALLOY C46400	1
24+	O-RING	SYNTH. RUBBER	COMMERCIAL	1
25+	MAIN VALVE STEM	(NOTE 12)	(NOTE 12)	1
26+	MAIN VALVE DISC	SYNTH, RUBBER	COMMERCIAL	1
27*	DISC HOLDER	BRONZE	ASTM-B139	1
28*	MAIN VALVE NUT	STAINLESS STEEL	AISI TYPE 302	1
29+	MAIN VALVE DISC COMPL.	RUBBER/BRONZE	COMMERCIAL	1
30*	RETAINING WASHER	BRONZE	ASTM-B21, ALLOY C46400	1
31*	ORIFICE DISC	STAINLESS STEEL	AISI TYPE 416	1
E) 1/2" - 4" GPSC-1 (CONSTANTEMP HEATER)				
1	ADAPTER	BRASS	ASTM-B16	1
2+	DIAPHRAGM SET (NOTE 15)	STAINLESS STEEL	AISI TYPE 316	1
5	DIAPHRAGM COVER	CARBON STEEL	ASTM-A285, GR. C	1
10*	SEAT RING	(NOTE 6)	(NOTE 6)	1

+ RECOMMENDED SPARE PARTS.

* THESE PARTS, PLUS RECOMMENDED SPARE PARTS, SHOULD BE ON HAND WHEN OVERHAULING THIS EQUIPMENT.

REFERENCE NUMBER — EACH SIZE

1/2"	3/4"	1"	1-1/2"	2"	3"	4"
60022	60022	60022	60023	60023	60024	60024
60028	60028	60028	60029	60029	60030	60030
60401	60402	60403	60405	60405	9569	11970
9821	9445	9544	9447	9447	—	—
—	—	—	—	—	59404	59404
50655-95	50655-95	50655-95	50656-95	50656-95	49855-95	49855-95
71556	71556	71556	71557	71557	49856	49856
60310	60310	60310	60310	60310	47792	47792
43335	43335	43335	43369	43369	—	—
23403	23403	24696	24676	24676	24730	24786
23656-94	23656-94	23656-94	23656-94	23656-94	47671-94	47671-94
36187	36187	38202	38557	38557	57114	47208
23405	23405	24614	43144	43144	—	—
23404	23404	24698	43142	43142	—	—
24801	24801	24699	38585	38585	24839	24857
—	—	—	—	—	57889	57891
—	—	—	—	—	58598	58599
48832	48832	48832	49725	49725	56631	56631
65394	65394	65394	65394	65394	(NOTE 3)	(NOTE 3)
55062	55062	55062	55063	55063	55064	55064
65395	65395	65395	65398	65398	56626	56626
60401	60402	60403	60405	60405	9569	11970

PARTS LIST, GPS-1 & VARIANTS:

WHEN ORDERING PARTS, GIVE SIZE, CLASS, PART NAME, AND PART REFERENCE NUMBER FROM TABLE BELOW. USE PART NUMBER ONLY TO LOCATE PART ON DRAWING.

PART NO.	PART NAME	MATERIAL	MATERIAL SPECIFICATION	QTY.
F) 1/2" - 4" GPSS-1 & 1/2" GPSS-1S (STAINLESS STEEL - WETTED):				
2 +	DIAPHRAGM	STAINLESS STEEL	AISI TYPE 316	2
5	DIAPHRAGM COVER	CARBON STEEL	ASTM-A285, GR. C	1
6	DIAPHRAGM DISC	STAINLESS STEEL	AISI TYPE 316	1
7 *	MAIN VALVE GUIDE	NITRONIC 60	ASTM-A276 UNS S21800	1
8	BODY THREADED	CAST SST	ASTM-A351, GR. CF8M	1
8	BODY S.O. FLG (NOTE 7)	CAST SST	ASTM-A351, GR. CF8M	1
8	BODY 150# FLG	CAST SST	ASTM-A351, GR. CF8M	1
8	BODY 300# FLG	CAST SST	ASTM-A351, GR. CF8M	1
8	BODY S.W.E.	CAST SST	ASTM-A351, GR. CF8M	1
10*	SEAT RING-1	(NOTE 6)	(NOTE 6)	1
10*	SEAT RING-1S	STELLITED SST	(NOTE 8)	1
12+	BOTTOM CAP GASKET	GRAPHITE w/SST 304	COMMERCIAL	1
13	BOTTOM CAP (NOTE 2)	CAST SST	ASTM-A351, GR. CF8M	1
14	BOTTOM CAP BUSHING	NITRONIC 60	ASTM-A276 UNS S21800	1
16	DIAPHRAGM BASE	CAST SST	ASTM-A351, GR. CF8M	1
G) 1/2" - 4" GPHS-1 (HIGH PRESSURE)				
2+	DIAPHRAGM	STAINLESS STEEL	AISI TYPE 316	3
3	BOLT	STEEL	ASTM-A193, GR. B7	(NOTE 1)
5	DIAPHRAGM COVER	CARBON STEEL	ASTM-A285, GR. C	1
10*	SEAT RING	STELLITED SST	(NOTE 13)	1

+ RECOMMENDED SPARE PARTS.

* THESE PARTS, PLUS RECOMMENDED SPARE PARTS, SHOULD BE ON HAND WHEN OVERHAULING THIS EQUIPMENT.

REFERENCE NUMBER — EACH SIZE

1/2"	3/4"	1"	1-1/2"	2"	3"	4"
46729	46729	46729	45953	45953	58640	58640
65395	95395	65395	65398	65398	42869	42869
72089	72089	72089	71792	71792	72090	72090
72092	72092	72092	72092	72092	72093	72093
71284-05	71276-05	71287-05	71290-05	71499-05	—	—
—	—	71286-05	71292-05	71294-05	—	—
—	—	—	—	—	71501-05	71503-05
—	—	—	—	—	71502-05	71504-05
72265-05	72267-05	72269-05	72271-05	72273-05	—	—
60401	60402	60403	60405	60405	9569	11970
9821	9445	9544	9447	9447	—	—
72459	72459	72460	72461	72461	72462	72471
72070-05	72070-05	72071-05	71795-05	71795-05	72066-05	72067-05
72069	72069	72068	71794	71794	—	—
—	—	—	—	—	71509-05	71510-05
46729	46729	46729	45953	45953	58640	58640
4021	4021	4021	4021	4021	72448	72448
72291	72291	72291	72292	72292	72360	72360
9821	9445	9544	9447	9447	9569	11970

- NOTE 1: QUANTITY IS 12 FOR 1/2" TO 1" & 2" SIZES, 14 FOR 1-1/2" SIZE, AND 20 FOR 3" & 4" SIZES.
- NOTE 2: BOTTOM CAP IS FURNISHED COMPLETE WITH BOTTOM CAP BUSHING, PART NO. 14. BUSHING CAN BE FURNISHED SEPARATELY FOR 1/2" TO 2" SIZES.
- NOTE 3: ADAPTER NOT REQUIRED FOR 3" & 4" SIZES.
- NOTE 4: INCLUDES EXTERNAL INTEGRAL ADAPTER FOR 1/2" TO 2" SIZES.
- NOTE 5: QUANTITY IS 6 FOR 3" SIZE AND 8 FOR 4" SIZE.
- NOTE 6: MATERIAL IS AISI TYPE 416 SST/FLUOROSINT FOR 1/2" TO 2" SIZES AND AISI TYPE 410 SST STELLITED FOR 3" AND 4" SIZES.
- NOTE 7: WHEN ORDERING REPLACEMENT BODY, RETAINING RING (PART NO. 21), AND SLIP-ON FLANGES (PART NO. 22 OR 23), MUST BE ORDERED SEPARATELY.
- NOTE 8: MATERIAL IS AISI TYPE 410 STELLITED FOR 1/2" TO 1" SIZES AND AISI TYPE 17-4 PH STELLITED FOR 1-1/2" AND 2" SIZES.
- NOTE 9: MATERIAL IS CARBON STEEL/COMMERCIAL FOR 1/2" TO 2" SIZES, AND CAST IRON/ASTM-A126 CL. B FOR 3" AND 4" SIZES.
- NOTE 10: FOR EXTERNAL PILOT AND TUBING KIT, SEE DRAWING 30/4.4.2.4.
- NOTE 11: MAIN VALVE COMPLETE MAY BE FURNISHED AS INDIVIDUAL PARTS. FOR 1/2" TO 2" SIZES, SEE PART NUMBERS 24,25, 26, 27, AND 28. FOR 3" AND 4" SIZES, SEE PART NUMBERS 24, 25, 28, 29 AND 30.
- NOTE 12: MATERIAL IS CAST BRONZE ASTM-B584 ALLOW UNS C90300 FOR 1/2" TO 2" SIZES AND ASTM-B21 ALLOY UNS C46400 TEMPER H02 FOR 3" AND 4" SIZES.
- NOTE 13: MATERIAL IS AISI TYPE 410 STELLITED FOR 1/2" TO 1", 3" AND 4" SIZES, AND AISI TYPE 17-4 PH STELLITED FOR 1-1/2" AND 2" SIZES.
- NOTE 14: FOR CAST IRON 'GPK' DIRECT, DIAPHRAGM OPERATED REDUCING VALVES, SEE DRAWING 30/4.4.1.1.
- NOTE 15: TWO LEAVES, BOTTOM DIAPHRAGM HAS BLEED HOLE.
- NOTE 16: ADAPTER NOT REQUIRED.
- NOTE 17: QUANTITY IS 20 FOR 3" AND 4" SIZES.