

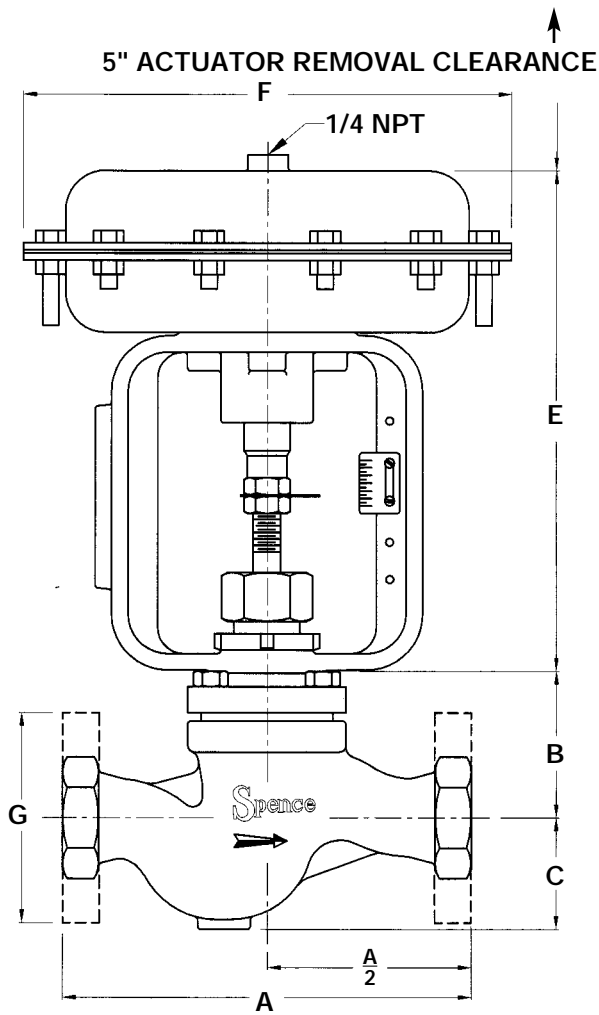

A Division of CIRCOR International, Inc.

SPENCE ENGINEERING COMPANY, INC. 150 COLDENHAM ROAD, WALDEN, NY 12586-2035

SD 8010A/0103



INTIMIDATOR TYPE J CONTROL VALVE

INTIMIDATOR TYPE J Control Valve Sizes 1/2" through 2"

The Intimidator Type J Valve has been designed for steam, water, gas and process applications in typical institutional, commercial and industrial processes. The Intimidator is available with either a direct or reverse acting actuator and meets most installation requirements.

PRESSURE/TEMPERATURE CHART

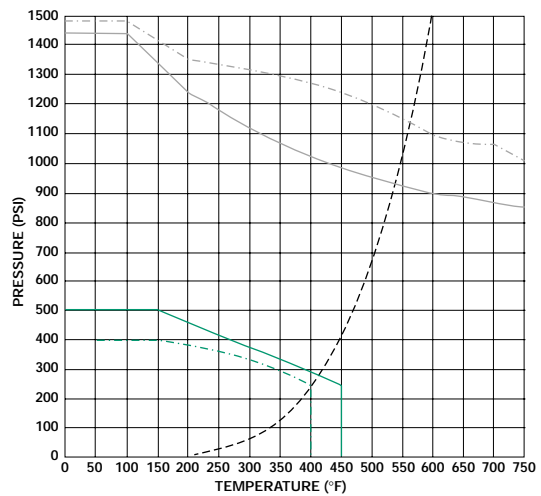

- SATURATED STEAM
- - - J2 ANSI/ASME B16.15 CLASS 250 CAST BRONZE
- J1 ANSI/ASME B16.1 CLASS 250 CAST IRON
- J4 ANSI/ASME B16.34 CLASS 600 STEEL
- - - J3 ANSI/ASME B16.34 CLASS 600 STAINLESS STEEL

MAXIMUM RATED FLOW COEFFICIENTS* (Cv)

VALVE SIZE				
1/2	3/4	1	1 1/2	2
5.1	10.3	18.2	37	67

DIMENSIONS inches AND WEIGHTS pounds

Size	A		B	C	E		F		G (Flange Diameter)		Weights*			
	Scrd.	Flg.**			36 in. ²	60 in. ²	36 in. ²	60 in. ²	150	300/600	Screwed		Flanged	
											36 in. ²	60 in. ²	36 in. ²	60 in. ²
1/2	7 5/8	8	2 11/16	1 7/8	9 5/8	11 1/8	9 1/4	11 1/4	3 1/2	3 3/4	20 1/2	36 1/2	23 1/2	39 1/2
3/4	7 5/8	8 1/8	2 11/16	1 7/8	9 5/8	11 1/8	9 1/4	11 1/4	3 7/8	4 5/8	20 1/2	36 1/2	25 3/4	41 3/4
1	7 3/4	8 1/4	2 3/4	2 1/8	9 5/8	11 1/8	9 1/4	11 1/4	4 1/4	4 7/8	22 1/2	38 3/4	29	45 1/4
1 1/2	9 1/4	9 5/8	33/8	2 11/16	9 5/8	11 1/8	9 1/4	11 1/4	5	6 1/8	29 1/4	45 1/2	40 1/4	57 1/2
2	10 1/2	11 1/4	3 3/32	3 5/16	9 5/8	11 1/8	9 1/4	11 1/4	6	6 1/2	38 1/4	54 1/4	50 1/4	68 1/4

*Weights are approximate.

** Flanges are 600# face-to-face with 1/4" raised face.

PRINTED IN U.S.A.

OPERATING PRINCIPLE

The Intimidator Type J Valve is a flow to open, globe style, pneumatic diaphragm actuated control valve. It can be arranged to operate with either air to close or air to open

control. A controller sensing the controlled variable provides an air signal to the actuator of the control valve to obtain the desired control.

RECOMMENDED INSTALLATION

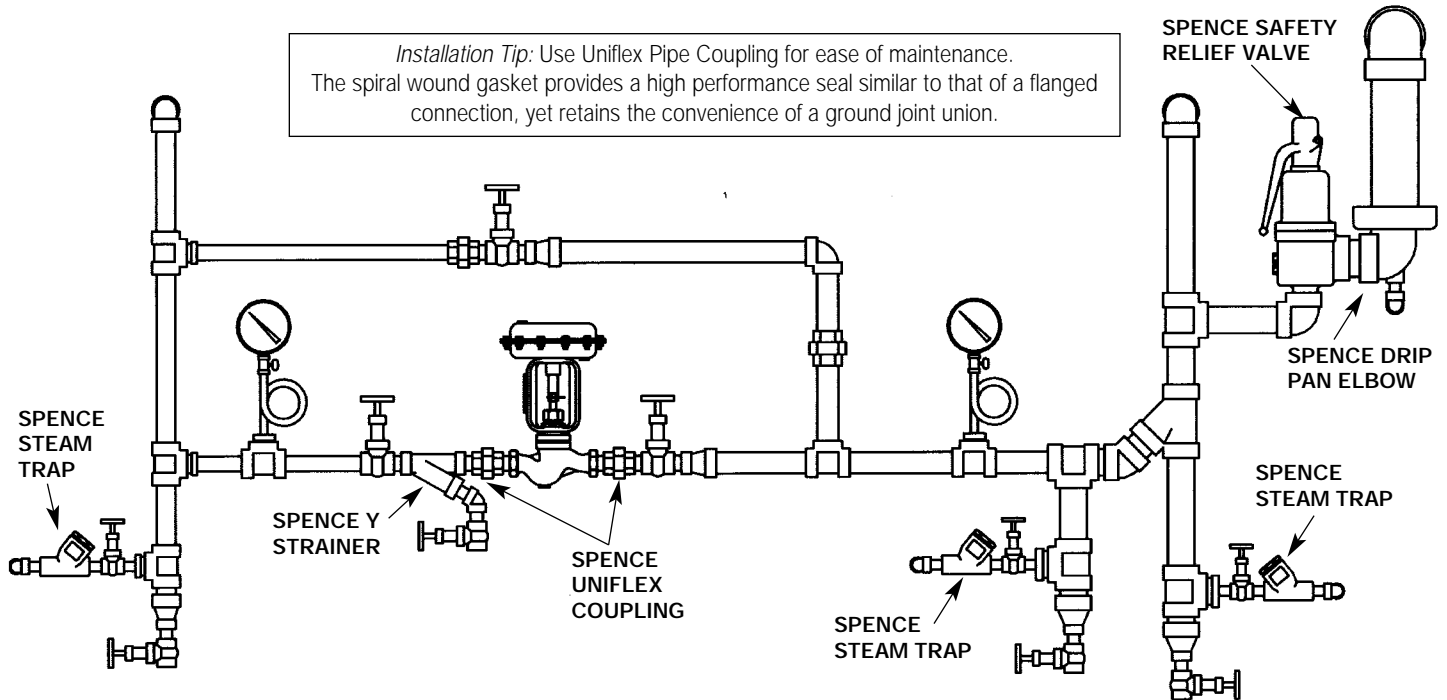

FIGURE 1 - Typical Steam Installation

INSTALLATION

Locate the valve in a straight run of horizontal pipe as shown in Figure 1. The valve should be mounted with the actuator in the upright position. Allow room for removal of the actuator. Prevent pipeline hammering in compressible fluid service by providing proper drainage before and after the valve. Avoid damaging effects of scale and dirt in pipelines by using a strainer. A 3-valve by-pass to facilitate inspection and maintenance without interrupting service is recommended. To eliminate excessive

noise with steam and other compressible fluids, enlarge the delivery pipe size to allow a reasonable flow velocity at the reduced pressure. A concentric transition is recommended. If possible, avoid sharp turns close to the valve. Install upstream and downstream pressure gauges to indicate performance. If the rating of the delivery system or connected equipment is less than the initial pressure, provide a safety relief valve.

START-UP AND SETTING

Flush the piping system thoroughly to clear it of welding beads, scale, sand, etc. Install the valve with the arrow on the side of the valve body pointing in the direction of fluid flow. Screwed end valves should be mounted between unions. Install controller and accessories in accordance with instructions furnished by the manufacturer of these items. Connect necessary air lines and/or electrical connections to the diaphragm chamber and

valve mounted accessories. Use 1/4" O.D. tubing for all air lines. If the length of the air line exceeds 25 ft, use 3/8" O.D. tubing. Insulation, may be applied to the valve body only. Do not insulate the bonnet. Caution: The valve may be handling hazardous fluids. Only qualified personnel, who are familiar with your installation, should be permitted to install, readjust, inspect or maintain the valve.

ACTUATOR SHUTOFF TABLE

PORT SIZE	ACTUATOR SIZE	BENCH RANGE	REVERSE SHUTOFF		BENCH RANGE	DIRECT SHUTOFF	
			3-15 PSI	0-20 PSI*		3-15 PSI	0-20 PSI
1/8	36	5 - 15	0 - 750	0 - 750	3 - 13	0 - 750	0 - 750
3/16, 1/4	36	5 - 15	0 - 250	0 - 750	3 - 13	0 - 250	0 - 750
5/8	36	5 - 15	—	0 - 50	3 - 10	0 - 300	0 - 750
		8 - 15	0 - 350	50 - 500	3 - 5	300 - 750	300 - 750
		10 - 15	350 - 550	500 - 750	—	—	—
7/8	36	8 - 15	0 - 200	0 - 300	3 - 10	0 - 150	0 - 350
		10 - 15	200 - 300	300 - 450	3 - 5	150 - 400	350 - 650
	60	8 - 15	0 - 500	0 - 700	3 - 11	0 - 300	0 - 600
		10 - 15	500 - 650	700 - 750	3 - 8	300 - 500	600 - 750
		12 - 15	650 - 750	—	—	—	—
1-1/4	36	—	—	—	3 - 10	0 - 150	0 - 300
		10 - 15	0 - 150	0 - 225	3 - 5	150 - 225	300 - 375
	60	8 - 15	0 - 200	0 - 300	3 - 11	0 - 150	0 - 350
		10 - 15	200 - 250	300 - 350	3 - 8	150 - 250	350 - 450
		12 - 15	250 - 300	350 - 400	—	—	—
		20 - 60**	—	0 - 750**	—	—	—
1-3/4	36	10 - 15	0 - 75	0 - 125	3 - 5	0 - 100	0 - 200
		8 - 15	0 - 75	0 - 125	3 - 11	0 - 100	0 - 200
	60	10 - 15	75 - 125	125 - 175	3 - 8	100 - 125	200 - 250
		12 - 15	125 - 175	175 - 225	—	—	—
		20 - 60**	—	0 - 375**	—	—	—
2-1/4	60	11 - 15	0 - 100	0 - 125	3 - 10	0 - 50	0 - 100
		20 - 60**	—	0 - 225**	—	—	—

* Based on 20 psi air supply w/ EPC or Positioner

** Based on 60 psi air supply w/ EPC or Positioner

NOTES:

- 1) For pressures over 750 psi please consult factory
- 2) For direct configured actuators 60 psi air signal will achieve 750 psi shutoff except for 2.25 port which will achieve 650 psi shutoff
- 3) Do not exceed 60 psi air signal to actuator

ACTUATOR SELECTION

Select Actuator size and bench range that will accommodate require shut off with port size selected. Select reverse for air to open fail close applications, direct for air to close fail open applications.

Cv TABLE

SIZE	TRAVEL	PORT SIZE	PLUG CONTOUR	PERCENT OF TRAVEL										
				5	10	20	30	40	50	60	70	80	90	100
1/2	3/4	1/8	EP	0.002	0.003	0.006	0.011	0.021	0.032	0.042	0.052	0.062	0.072	0.08
		3/16	EP	0.004	0.008	0.014	0.021	0.03	0.045	0.063	0.095	0.145	0.25	0.5
		1/4	EP	0.03	0.04	0.07	0.12	0.18	0.25	0.36	0.49	0.7	1.1	1.5
		5/8	MEP	0.05	0.1	0.18	0.31	0.49	0.73	1.1	1.6	2.3	3.4	5.1
3/4	3/4	1/8	EP	0.002	0.003	0.006	0.011	0.021	0.032	0.042	0.052	0.062	0.072	0.08
		3/16	EP	0.004	0.008	0.014	0.021	0.03	0.045	0.063	0.095	0.145	0.25	0.5
		1/4	EP	0.03	0.04	0.07	0.12	0.18	0.25	0.36	0.49	0.7	1.1	1.5
		5/8	MEP	0.05	0.07	0.18	0.31	0.47	0.73	1.1	1.6	2.4	3.8	6
		7/8	MEP	0.07	0.19	0.58	1	1.3	1.9	2.5	3.8	5.7	8.7	10.3
1	3/4	5/8	MEP	0.04	0.07	0.16	0.31	0.54	0.79	1.1	1.8	2.2	4	6.2
		7/8	MEP	0.07	0.15	0.42	0.75	1.2	1.9	2.9	4.2	6.7	9.8	12.1
		1-1/4	MEP	0.09	0.27	0.63	1	1.4	3.2	5.3	7.5	11.5	15.6	18.2
1-1/2	3/4	7/8	MEP	0.11	0.21	0.54	0.89	1.4	1.9	2.7	3.9	6.4	10.1	13.2
		1-1/4	MEP	0.14	0.37	0.99	1.5	2.4	3.6	5.3	7.5	12.3	16.8	22
		1-3/4	MEP	0.41	0.85	2.4	4.3	6.4	9.9	15.7	22.7	29	34.2	37
2	3/4	1-1/4	MEP	0.14	0.37	0.99	1.5	2.4	3.6	5.3	7.5	12.3	17.3	23
		1-3/4	MEP	0.41	0.85	2.4	4.3	6.5	10	16	23	31	37	43
	1-1/16	2-1/4	MEP	0.75	1.5	3.5	6.5	10.5	15.5	26	39	50	60	67

PRODUCT IDENTIFICATION

ORDERING CODE

MODEL NUMBER (2 Digits)	ORIFICE (2 Digits)	SIZE (2 Digits)	CONNECTIONS (2 Digits)	TRIM (2 Digits)	PACKING (2 Digits)	ACTUATOR (2 Digits)	SPRING # (2 Digits)	POSITIONER (2 Digits)	POSIT. SET (2 Digits)	ACCESSORIES (2 Digits)	INLET PRESSURE (3 Digits)
example: <u>J1</u>	<u>J</u>	<u>C</u>	<u>9</u>	<u>1</u>	<u>1</u>	<u>—</u>	<u>36</u>	<u>RM</u>	<u>MP</u>	<u>02</u>	<u>01</u> — <u>125</u>
J1 - Cast Iron	F - 1/8	C - 1/2	1 - 150	1 - Metal	1 - V-ring	01 - None	DC - 3-13 Dir 36	AA - None	01 - None	01 - None	
J2 - Bronze	G - 3/16	D - 3/4	3 - 250/300	2 - Soft	2 - Graphite	36 - 36 in ²	DD - 3-10 Dir 36	EI - Eckardt I/P	02 - 3-15/4-20mA	02 - Limit Switch-Mechanical	
J3 - Stainless	H - 1/4	E - 1	6 - 600#		3 - Hi-Temp	60 - 60 in ²	DE - 3-5 Dir 36	EP - Eckardt P	03 - 3-9/4-12mA	03 - Limit Switch-Proximity Switch	
J4 - Cast Steel	J - 3/8	G - 1 1/2	9 - Threaded				DF - 3-10 Dir 60*	MI - Moore I/P	04 - 9-15/12-20mA	04 - Feedback-Potentiometer 1K	
	K - 7/8	H - 2					DG - 3-11 Dir 60	MP - Moore P		05 - Feedback-4-20mA Pos. Trans	
	L - 1 1/4						DH - 3-8 Dir 60	4P - PMV P4 P			
	M - 1 3/4						RC - 5-15 Rev 36	5I - PMV P5 I/P			
	N - 2 1/4						RD - 8-15 Rev 36	5P - PMV P5 P			
							RE - 10-15 Rev 36				
							RG - 8-15 Rev 60				
							RH - 10-15 Rev 60				
							RJ - 11-15 Rev 60*				
							RK - 20-60 Rev 60				
							RL - 20-60 Rev 60*				
							RQ - 12-15 Rev 60				

* 2 1/4" port only.

USE SUFFIX -1 FOR SUBASSEMBLY (i.e.: J1KE911-1)

TROUBLESHOOTING

For troubleshooting of the controlling device and accessories, see the instruction furnished by the manufacturer of these items. To troubleshoot the valve and actuator, check for the following: change in operating conditions; pneumatic signal failure; diaphragm failure; foreign matter lodged between seat ring and plug; actuator vent plug may be: plugged, missing, replaced with a solid plug; packing leakage.

Graphite Packing – Figure 4

If packing leaks, tighten packing nut as necessary until leakage stops. Over-tightening of packing nut may cause erratic operation. Install additional center packing rings. This can be

accomplished by loosening packing nut (32). Lift packing nut, gland and end packing ring a sufficient height on stem and plug assembly (26) to apply packing ring. Insert one skive cut center packing ring over diameter of stem and plug assembly into packing box. Replace end packing ring and tighten packing nut as necessary to stop leakage. Replace packing.

Teflon Packing – Figure 4

If the packing leaks, isolate and depressurize the valve. Check the stem for gouges and that the o-ring is properly seated. Install replacement packing, if necessary, then return the valve to service.

MAINTENANCE

REMOVAL OF THE ACTUATOR FROM THE VALVE BODY ASSEMBLY

Close inlet and outlet stop valves. Be sure valve body is not under pressure. Remove all accessories from the control valve. Refer to Figure 5.

Reverse Acting Actuator

Loosen stem nuts (31) and move to approximately 1/3 down valve stem. Re-tighten, being careful not to move valve stem. Energize actuator with air to lift plug off seat. Disengage packing nut (32) and lock nut (33) from bonnet (25). De-energize actuator. Actuator and yoke should move away from bonnet. Lift

actuator and yoke assembly along with plug and stem assembly (27) off seat. With a 1/4' wrench, unthread valve stem from the actuator stem (16) until valve stem is disengaged from actuator stem. Remove stem nuts, indicator, packing nut and lock nut.

Direct Acting Actuator

Energize actuator with air slightly (in case of back seating). Loosen stem nuts (31) and re-tighten approximately 1/8" away from actuator stem (16). Disengage packing nut (32) and lock nut (33) from bonnet (25). With a 1/4' wrench, unscrew valve stem from actuator stem. When valve stem reaches seat, lift actuator (to prevent galling the seat and plug). Remove stem nuts, indicator, packing nut and lock nut.

DISASSEMBLY OF THE VALVE BODY

Remove stem nuts (31), indicator (22), packing nut (32) and lock nut (33) as shown in Figure 2. Lift yoke off the bonnet (25). Remove bonnet bolts (23) and lift off bonnet flange (24), bonnet and stem and plug assembly (27). Remove gasket (26). A new gasket should be installed each time the valve body is disassembled. Turn stem and plug assembly out of the bonnet through packing. Replace packing if necessary. All parts should be inspected for wear and cleaned thoroughly before re-assembling the valve body.

DISASSEMBLY OF THE ACTUATOR

Remove actuator from the valve. Remove regular casing bolts (4) and casing nuts (5). Gradually loosen nuts on the remaining long casing bolts (14) to allow pre-compression of actuator springs. Remove upper casing (2). Pull actuator stem (16), along with diaphragm (15), springs (3) and piston (13), out through bushing (7). Place a wrench on machined flats of the actuator stem and remove stem nut (10), seal washer (12) and stem washer (11). Remove o-ring (8) from the bushing and replace if necessary. Lubricate o-ring after installing.

RE-ASSEMBLY OF THE ACTUATOR

Refer to Figure 5 for correct orientation of casings, diaphragm (15), piston (13), stem (16) and springs (3) for direct or reverse action. Be sure that piston spring recesses line up between casing ribs as shown in Figure 6B for all springs except 05-13085-00 and 05-13097-00 which are assembled per Figure 6A. Note that seal washer rings and stem washer are below the diaphragm for 8-15 psi on the 36 in² actuator as shown in Figure 7. For all other springs, the seal and stem washers are assembled above the diaphragm. Lubricate bushing o-ring (8) and insert actuator stem through the bushing. Re-attach upper casing (2) with long bolts (14) & nuts (5), tightening alternately. Install remaining casing nuts and bolts. Apply air to diaphragm case and check for leakage, full travel and dead band less than .2 psi.

LAPPING PLUG INTO THE SEAT

Remove old packing from the packing box with a hook type tool or with compressed air in the body. Seats and plugs should never require more than the lightest touch up with very fine (400 grit) grinding compound. Heavy lapping will produce galling, a wider seating surface and a groove in the plug, all of which tend to cause leakage. Reface a damaged surface before attempting to grind it in. Lap sparingly. Replace stem and plug assembly (27) in bonnet (25) through packing. Apply lapping compound to the plug. Place bonnet and bonnet flange (24) on the body and tighten bonnet bolt (23) finger tight. Do not tighten packing nut (32) during the lapping operation. After lapping, disassemble and clean all parts thoroughly.

PACKING REPLACEMENT

Install packing o-ring followed by a washer onto plug and stem assembly on valve sub-assembly. Lubricate o-ring with silicone lubricant. Use a 1/4" schedule 40 pipe to firmly seat the o-ring into the o-ring groove. Install remaining packing, packing follower and packing nut referring to Figure 4. Note that packing follower is reversible for either braided packing or TFE packing. Warning - stem should not be stroked without packing nut being tightened or packing o-ring may become dislodged. Forcing stem threads through installed packing will damage packing.

RE-ASSEMBLY OF THE VALVE BODY

Install a new gasket (26). Attach bonnet (25) and bonnet flange (24) to body with bonnet bolts (23). Be sure to tighten bolts alternately and evenly to insure proper seating of the plug. Replace yoke (9), lock nut (33), packing nut (32), stem nuts (31), travel indicator (22), over plug and stem assembly (27).

REPLACING THE ACTUATOR ON THE VALVE BODY

Put actuator assembly over the valve stem. Place lock nut (33), packing nut (32) and stem nuts (31) with travel indicator (22) on valve stem. Rest actuator stem (16) on valve stem. Tighten stem nuts approximately 2/3 down valve stem. Lift actuator assembly and engage valve stem with actuator stem (be careful not to gall the plug & seat).

Reverse Acting

When sufficient engagement is met, actuator can be energized with air to place yoke on the bonnet (25) and lift plug off the seat. Tighten lock nut and packing nut.

Direct Acting

Engage valve stem with actuator stem so no contact is made between plug and seat when the bottom of the yoke is rested on the bonnet. Tighten lock nut and packing nut.

ACTUATOR ADJUSTMENT

Close inlet and outlet stop valves. Be sure valve body is not under pressure. Place wrench on machined flats of actuator stem (16). Turn stem nuts (31) approximately halfway down threads of plug & stem assembly (27) and counter the two nuts.

Reverse Acting

Apply sufficient air pressure to diaphragm case to start moving the valve through its rated travel. This is shown by the travel indicator (22). Engage lower stem nut (31) and turn plug & stem assembly (27) into actuator stem (16) until pre-compression of actuator springs (3) is relieved (plug should not be seating on seat ring when air pressure is removed from actuator case). Apply prescribed setting pressure to actuator. This is determined by specific operating conditions. Turn plug & stem assembly out of actuator stem until plug seats on seat ring (28). To prevent galling, do not turn plug & stem assembly once plug has contacted seat ring. Turn stem nuts up plug & stem assembly and tighten to lock it in position. Reduce air signal to 0 psi and calibrate indicator scale (20). Check that full travel is achieved with a 15 psi signal, except for 20-60 psi springs.

Direct Acting

Engage lower stem nut (31) and turn plug & stem assembly (27) into actuator stem (16) until plug & stem assembly stops at upper limit of travel and/or a slight downward movement of actuator stem is detected. Turn stem nut up the plug & stem assembly and tighten to lock in position. Calibrate indicator scale (20). Check that full travel is achieved at a 0 psi signal, except for 20-60 springs.

When ordering parts, it is essential that the valve type, size, service and serial number be stated.

Select part by item number, but order by part number.

Specify complete part number when ordering.

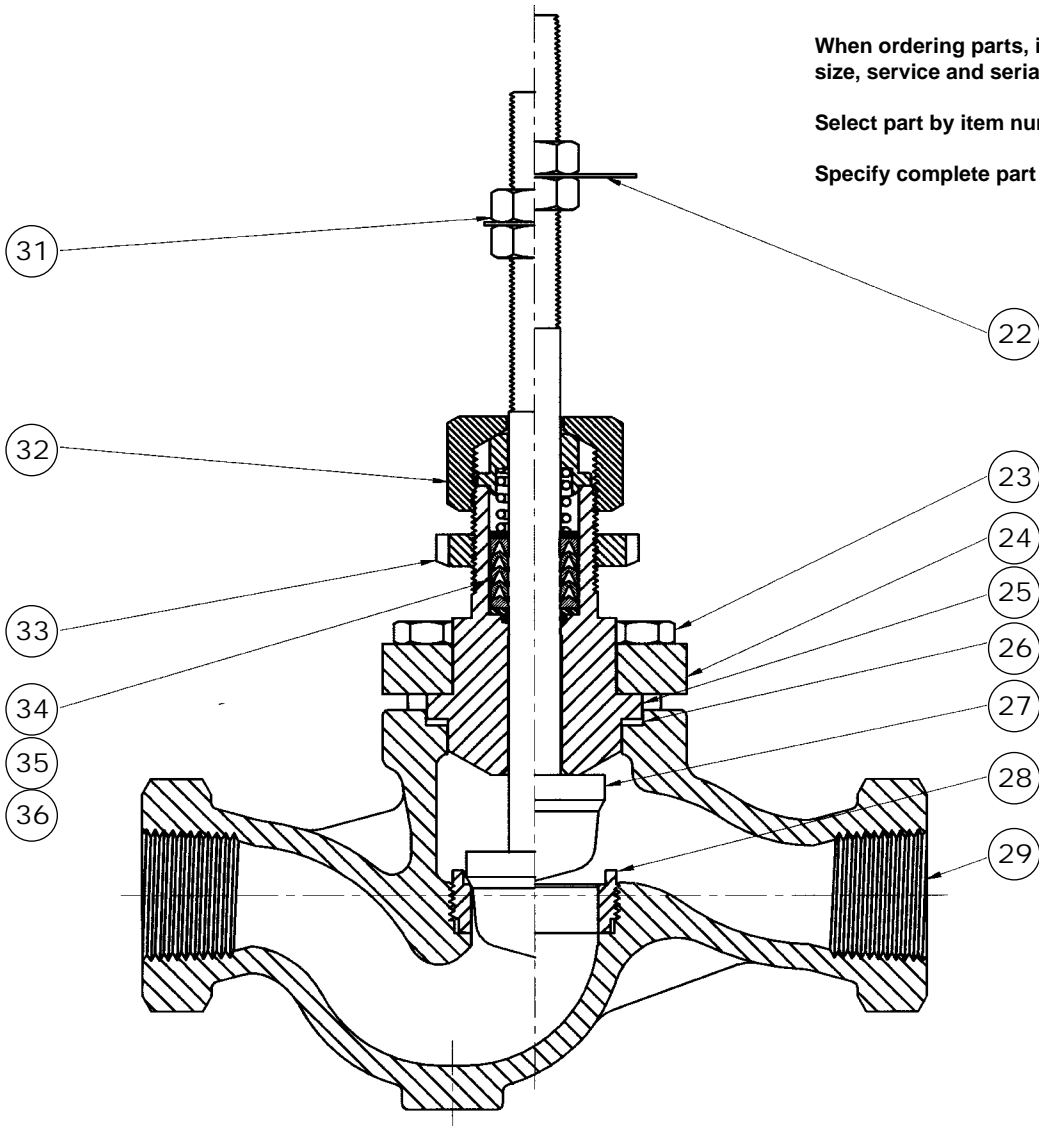

FIGURE 2 - VALVE BODY ASSEMBLY

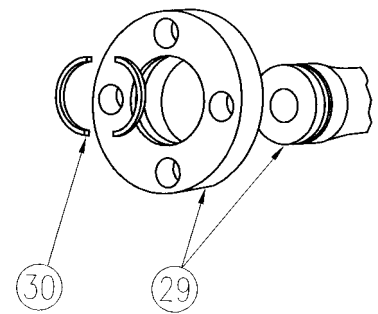

FIGURE 3 - SLIP ON FLANGE ASSEMBLY

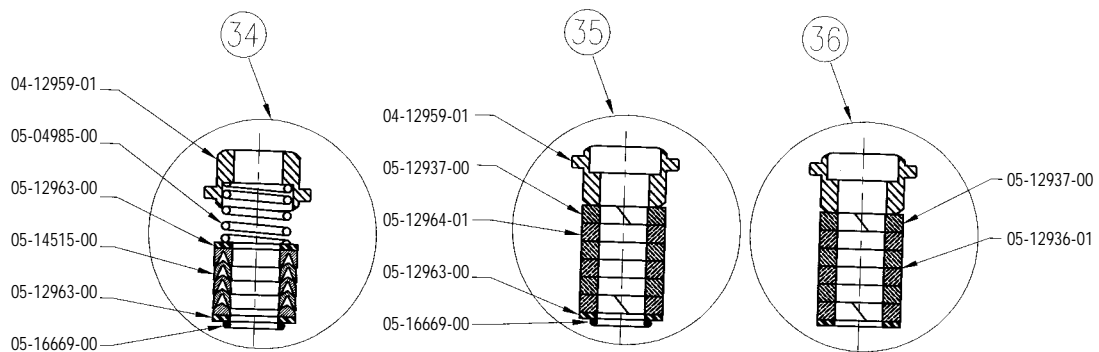

FIGURE 4 - PACKING ASSEMBLY

VALVE BODY ASSEMBLY PART NUMBERS

ITEM NO.	PART NAME	MATERIAL	VALVE SIZE				
			1/2	3/4	1	1-1/2	2
22	TRAVEL INDICATOR	ALUM	05-12962-00	05-12962-00	05-12962-00	05-12962-00	05-12962-00
23	BONNET BOLT	STL	05-17301-00	05-17301-00	05-17302-00	05-17303-00	05-17304-00
24	BONNET FLANGE	STL	04-13918-00	04-13918-00	04-13919-00	04-13920-00	04-13921-00
25	BONNET 316 SS VALVES	316SS	04-13549-00	04-13549-00	05-13549-00	04-13550-00	04-13551-00
	BONNET CI & STEEL	STL	04-12983-00	04-12983-00	04-12956-00	04-13125-00	04-13189-00
	BONNET BRZ	BRASS	04-13870-00	04-13870-00	04-13871-00	04-13872-00	04-13873-00
26*	GASKET, CI & BZ	GRAPHITE	05-13395-00	05-13395-00	05-13396-00	05-13397-00	05-16398-00
	GASKET, STEEL & SST	GRAPHITE	05-13396-00	05-13396-00	05-13396-00	05-13397-00	05-16398-00
27	PLUG/STEM, EQ% 1/8	316SS	04-13848-00	04-13848-00	—	—	—
	PLUG/STEM, EQ% 3/16	316SS	04-13178-00	04-13178-00	—	—	—
	PLUG/STEM, EQ% 1/4	316SS	04-13564-00	04-13564-00	04-13564-00	—	—
	PLUG/STEM, EQ% 5/8	316SS	04-13565-00	04-13565-00	04-13565-00	—	—
	PLUG/STEM, EQ% 7/8	316SS	—	04-13566-00	04-13566-00	04-13566-00	—
	PLUG/STEM, EQ% 1-1/4	316SS	—	—	04-13567-00	04-13567-00	04-13894-00
	PLUG/STEM, EQ% 1-3/4	316SS	—	—	—	04-13568-00	04-13887-00
	PLUG/STEM, EQ% 2-1/4	316SS	—	—	—	—	04-13569-00
	PLUG/STEM, COMP 1/4	316SS	0@-13412-00	0@-13412-00	0@-13412-00	—	—
	PLUG/STEM, COMP 5/8	316SS/TFE	0@-13413-00	0@-13413-00	0@-13413-00	—	—
	PLUG/STEM, COMP 7/8	316SS/TFE	—	0@-13414-00	0@-13414-00	0@-13414-00	—
	PLUG/STEM, COMP 1-1/4	316SS/TFE	—	—	0@-13415-00	0@-13415-00	0@-13419-00
	PLUG/STEM, COMP 1-3/4	316SS/TFE	—	—	—	0@-13416-00	0@-13418-00
	PLUG/STEM, COMP 2-1/4	316SS/TFE	—	—	—	—	0@-13417-00
28	SEAT RING 1/8 CI/BRZ	17-4 PH	04-13847-00	04-13847-00	—	—	—
	SEAT RING 1/4 CI/BRZ	316SS	04-13173-01	04-13173-01	04-13525-00	—	—
	SEAT RING 5/8 CI/BRZ	316SS	04-12981-00	04-12981-00	04-13526-00	—	—
	SEAT RING 7/8 CI/BRZ	316SS	—	04-12982-00	04-13527-00	—	—
	SEAT RING 1/8 SST/STL	17-4 PH	04-14299-00	04-14299-00	04-14299-00	—	—
	SEAT RING 1/4 SST/STL	316SS	04-13525-00	04-13525-00	04-13525-00	—	—
	SEAT RING 5/8 SST/STL	316SS	04-13526-00	04-13526-00	04-13526-00	—	—
	SEAT RING 7/8 SST/STL	316SS	—	04-13527-00	04-13527-00	04-13529-00	—
	SEAT RING 1-1/4	316SS	—	—	04-13528-00	04-13530-00	04-13532-00
	SEAT RING 1-3/4	316SS	—	—	—	04-13531-00	04-13533-00
	SEAT RING 2-1/4	316SS	—	—	—	—	04-13534-00
	SEAT RING 1/4 COMP CI/BRZ	316SS	04-13399-00	04-13399-00	04-13400-00	—	—
	SEAT RING 5/8 COMP CI/BRZ	316SS	04-13401-00	04-13401-00	04-13402-00	—	—
	SEAT RING 7/8 COMP CI/BRZ	316SS	—	04-13491-00	04-13404-00	—	—
	SEAT RING 1/4 COMP SST/STL	316SS	04-13400-00	04-13400-00	04-13400-00	—	—
	SEAT RING 5/8 COMP SST/STL	316SS	04-13402-00	04-13402-00	04-13402-00	—	—
	SEAT RING 7/8 COMP SST/STL	316SS	—	04-13404-00	04-13404-00	04-13405-00	—
	SEAT RING 1-1/4 COMP	316SS	—	—	04-13406-00	04-13707-00	04-13408-00
	SEAT RING 1-3/4 COMP	316SS	—	—	—	04-13409-00	04-13410-00
	SEAT RING 2-1/4 COMP	316SS	—	—	—	—	04-13411-00
29	BODY NPT ENDS	STL	04-12979-00	04-12980-00	04-13063-00	04-13097-00	04-13196-00
	BODY NPT ENDS	BRZ	04-13849-00	04-13850-00	04-13851-00	04-13852-00	04-13853-00
	BODY NPT ENDS	316SS	04-13576-00	04-13580-00	04-13584-00	04-13588-00	04-13592-00
	BODY NPT ENDS	STL	04-13596-00	04-13600-00	04-13604-00	04-13608-00	04-13612-00
	BODY FLANGED ENDS	316SS	04-13579-00	04-13583-00	04-13587-00	04-13591-00	04-13595-00
	BODY FLANGED ENDS	STL	04-13599-00	04-13603-00	04-13607-00	04-13611-00	04-13617-00
	FLANGE SLIP ON 150#	STL	04-13628-00	04-13631-00	04-13634-00	04-13637-00	04-13640-00
	FLANGE SLIP ON 300#	STL	04-13629-00	04-13632-00	04-13635-00	04-13638-00	04-13641-00
	FLANGE SLIP ON 600#	STL	04-13630-00	04-13633-00	04-13636-00	04-13639-00	04-13642-00
30	RETAINER RING	STL	04-14077-00	04-14078-00	04-14079-00	04-14080-00	04-14081-00
31	STEM NUT	STL	05-12972-00	05-12972-00	05-12972-00	05-12972-00	05-12972-00
32	PACKING NUT	ST STL	04-12958-00	04-12958-00	04-12958-00	04-12958-00	04-12958-00
33	LOCK NUT	PLTD/STL	04-12961-00	04-12961-00	04-12961-00	04-12961-00	04-12961-00
34*	V RING PACKING SET	—	07-12932-00	07-12932-00	07-12932-00	07-12932-00	07-12932-00
35*	BRAIDED TFE/GRAPH PKG SET	—	07-12933-00	07-12933-00	07-12933-00	07-12933-00	07-12933-00
36*	HIGH TEMP GRAPH PKG SET	—	07-12936-00	07-12936-00	07-12936-00	07-12936-00	07-12936-00

* Recommended Spare Parts.

ACTUATOR PARTS

ITEM #	NAME	QTY	MATERIAL
1	VENT PLUG	1	H. D. POLY
2	UPPER CASING	1	STL/EPOXY
3	SPRINGS	VARIES	STL/EPOXY
3A	SPRING RETAINER	12	STL/EPOXY
4	CASING BOLT, REGULAR	10/14	304SS
5	CASING NUT	12/16	316SS
6	LOWER CASING	1	STL/EPOXY
7	BUSHING	1	BRONZE
8*	O RING	1	BUNA-N
9	YOKE	1	CI/EPOXY
10*	STEM NUT	1	STL/EPOXY
11*	STEM WASHER	1	316SS
12*	SEAL WASHER	1	STEEL
13	PISTON	1	316SS
14	CASING BOLT, LONG	2	304SS
14A	CASING BOLT, LONG†	2	STL/ZINC PLATE
15*	DIAPHRAGM	1	NITRILE
16	ACTUATOR STEM	1	303SS
17	MACHINE SCREW	3	STEEL
18	CASING GASKET	1	BUNA-N
19	MACHINE SCREW	1	ALUM
20	INDICATOR SCALE	1	ALUM
21	SPECIFICATION PLATE	2	STEEL

*These parts furnished in Actuator Repair Kit.

† For spring range 10-15 on 36 sq. in. actuator and 12-15 on 60 sq. in. actuator.

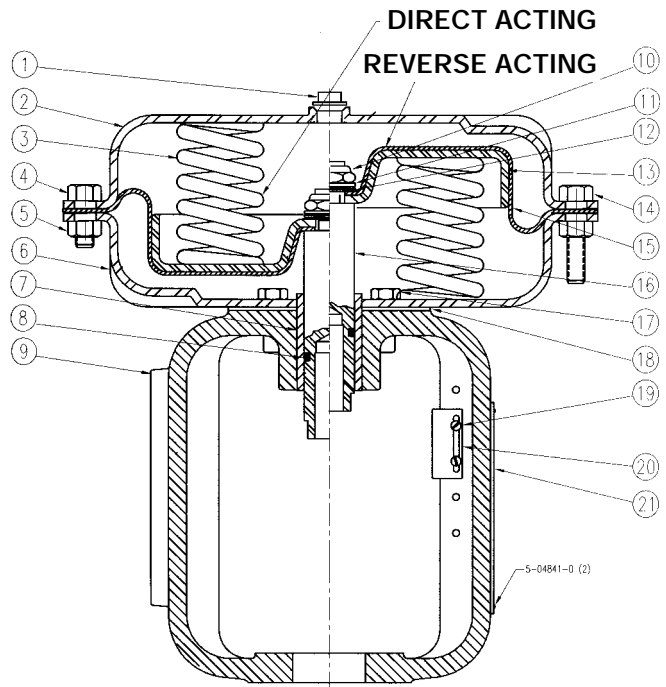

FIGURE 5 - ACTUATOR ASSEMBLY

ACTUATOR REPAIR KIT PART NUMBERS

36 SQ. IN.	60 SQ. IN.
51447	51448

ACTUATOR, SPRING KIT & SPRING PART NUMBERS

ACT. ASSY	SPRING KIT PN	Bench Ranges		Springs			Bolt (2)
		Reverse	Direct	Qty	Part #	Color	
36RC-ASM†	36RC	5-15	3-13	6	5-13090-1	RED	—
36RD-ASM†	36RD	8-15	3-10	4	5-13090-1	RED	—
36RE-ASM	36RE	10-15	—	6	5-13085-0	GREEN	5-04889-0
36DE-ASM	36DE	—	3-5	3	5-13087-0	GREEN	—
60RG-ASM†	60RG	8-15	3-11	6	5-13093-1	BROWN	—
60RH-ASM†	60RH	10-15	3-8 ³ / ₁₆ -10**	4	5-13093-1	BROWN	—
60RJ-ASM	60RJ	12-15 ³ / ₁₆ -15**	—	6	5-13097-0	BLACK	5-04889-0
60RK-ASM	60RK	20-60	—	6	5-13094-0	GRAY	—
60RL-ASM	60RL	20-60	—	6	5-13095-0	BLUE	—
				6	5-13096-0	BLUE	—

† Includes both J & K Valve travel scales.

* 3/4" travel

** 1-1/16" travel

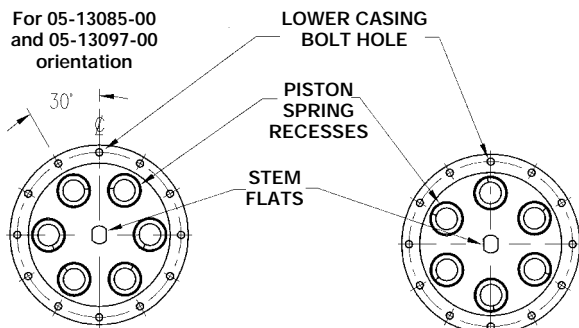
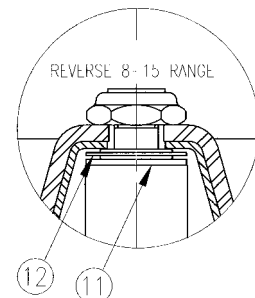

FIGURE 6A

FIGURE 6B

PISTON DIAPHRAGM ASSEMBLY



**FIGURE 7 - STEM ASSEMBLY
REVERSE 8-15 SPRING RANGE ONLY**